

# R&S® TS-PIO3B

## Digital I/O Module

### User Manual

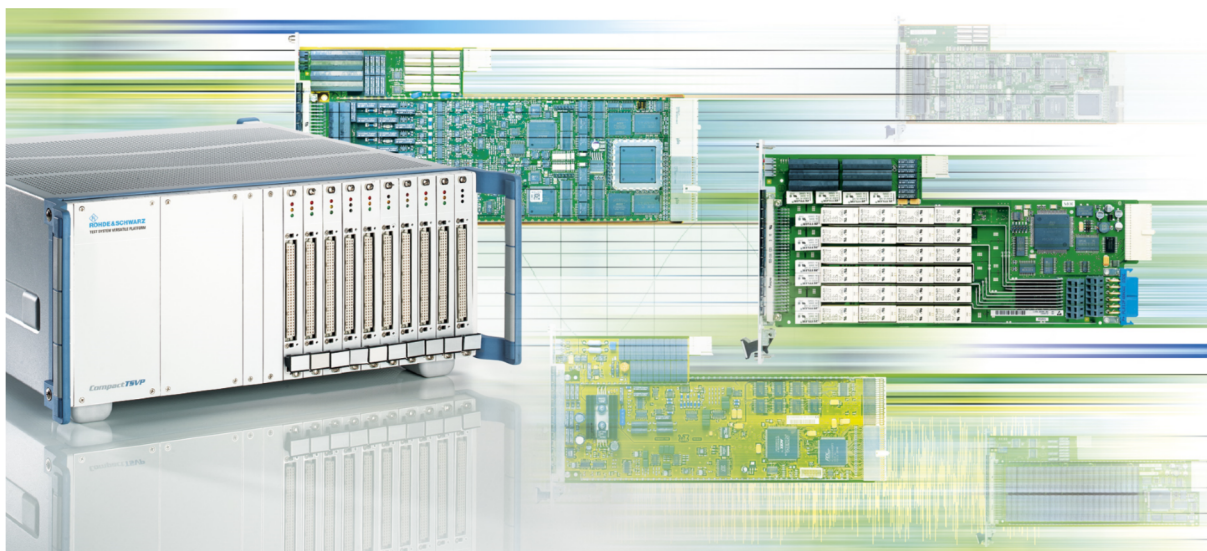

1512352312  
Version 07

**ROHDE & SCHWARZ**  
Make ideas real



This manual describes the following R&S®TSVP modules:

- R&S®TS-PIO3B
- R&S®TS-PTR
- R&S®TS-PRIO4
- R&S®TS-PTRF
- R&S®TS-PXM1

© 2022 Rohde & Schwarz GmbH & Co. KG  
Muehldorfstr. 15, 81671 Muenchen, Germany  
Phone: +49 89 41 29 - 0  
Email: [info@rohde-schwarz.com](mailto:info@rohde-schwarz.com)  
Internet: [www.rohde-schwarz.com](http://www.rohde-schwarz.com)

Subject to change – data without tolerance limits is not binding.

R&S® is a registered trademark of Rohde & Schwarz GmbH & Co. KG.

Trade names are trademarks of the owners.

1512.3523.12 | Version 07 | R&S®TS-PIO3B

The following abbreviations are used throughout this manual: R&S®PIO3B is abbreviated as R&S PIO3B, R&S®PTR as R&S PTR, R&S®PRIO4 as R&S PRIO4, R&S®PTRF as R&S PTRF, R&S®PXM1 as R&S PXM1.

# Contents

<b>1</b>	<b>Safety information (multilingual)</b> .....	<b>7</b>
<b>2</b>	<b>Documentation overview</b> .....	<b>11</b>
2.1	Getting started manual.....	11
2.2	User manuals.....	11
2.3	System manual.....	12
2.4	Service manual.....	12
2.5	Printed safety instructions.....	12
2.6	Brochures and specifications.....	12
2.7	Release notes and open source acknowledgment.....	12
<b>3</b>	<b>Welcome to the R&amp;S TS-PIO3B</b> .....	<b>13</b>
<b>4</b>	<b>Module tour</b> .....	<b>16</b>
4.1	<b>R&amp;S TS-PIO3B</b> .....	<b>16</b>
4.1.1	Open drain I/O ports.....	16
4.1.2	TTL port.....	18
4.1.3	Analog inputs.....	19
4.1.4	SPI.....	20
4.1.5	Voltage sources.....	20
4.1.6	Other interface signals.....	23
4.2	<b>R&amp;S TS-PRIO4</b> .....	<b>23</b>
4.2.1	Status LEDs.....	24
4.2.2	Passive wiring.....	24
4.3	<b>R&amp;S TS-PTR</b> .....	<b>24</b>
4.3.1	Passive wiring.....	25
4.3.2	Voltage sources.....	25
4.4	<b>R&amp;S TS-PTRF</b> .....	<b>25</b>
4.4.1	Status LEDs.....	26
4.4.2	Wiring of the open drain I/O ports and the analogue inputs of the R&S TS-PIO3B.....	27
4.4.3	Function of port P9.TIO of the R&S TS-PIO3B.....	28
4.4.4	SPI.....	28
4.4.5	+5 V / +12 V voltages.....	29

4.4.6	Analogue bus access.....	30
<b>4.5</b>	<b>R&amp;S TS-PXM1.....</b>	<b>30</b>
4.5.1	Status LEDs.....	30
4.5.2	Relay wiring.....	31
<b>5</b>	<b>Installation.....</b>	<b>33</b>
<b>6</b>	<b>Typical applications.....</b>	<b>35</b>
<b>6.1</b>	<b>Control of relays / pneumatic valves / vacuum valves.....</b>	<b>35</b>
<b>6.2</b>	<b>Adapter identification.....</b>	<b>35</b>
6.2.1	Parallel adapter identification via ports.....	35
6.2.2	Serial adapter identification via SPI-EEPROM.....	36
<b>7</b>	<b>Software.....</b>	<b>37</b>
<b>7.1</b>	<b>Driver software.....</b>	<b>37</b>
<b>7.2</b>	<b>Soft panel.....</b>	<b>37</b>
<b>7.3</b>	<b>Sample programs.....</b>	<b>38</b>
7.3.1	Programming with DIOMGR.....	38
7.3.2	Programming with signal routing library.....	41
7.3.3	Programming with device drivers.....	44
<b>8</b>	<b>Maintenance, storage and disposal.....</b>	<b>46</b>
<b>8.1</b>	<b>Changing fuses.....</b>	<b>46</b>
<b>8.2</b>	<b>Storage.....</b>	<b>46</b>
<b>8.3</b>	<b>Disposal.....</b>	<b>46</b>
<b>9</b>	<b>Troubleshooting.....</b>	<b>48</b>
<b>9.1</b>	<b>LED test.....</b>	<b>48</b>
<b>9.2</b>	<b>R&amp;S TSVP self-test.....</b>	<b>48</b>
9.2.1	Automatic detection.....	48
9.2.2	Fuse test.....	48
<b>9.3</b>	<b>Contacting customer support.....</b>	<b>49</b>
	<b>Annex.....</b>	<b>50</b>
<b>A</b>	<b>Specifications.....</b>	<b>50</b>
<b>B</b>	<b>Block diagrams.....</b>	<b>51</b>
<b>B.1</b>	<b>R&amp;S TS-PIO3B.....</b>	<b>51</b>

<b>B.2</b>	<b>R&amp;S TS-PRIO4.....</b>	<b>52</b>
<b>B.3</b>	<b>R&amp;S TS-PTR.....</b>	<b>52</b>
<b>B.4</b>	<b>R&amp;S TS-PTRF.....</b>	<b>54</b>
<b>B.5</b>	<b>R&amp;S TS-PXM1.....</b>	<b>56</b>
<b>C</b>	<b>Interface description.....</b>	<b>59</b>
<b>C.1</b>	<b>R&amp;S TS-PIO3B.....</b>	<b>59</b>
C.1.1	X10 connector on the front.....	59
C.1.2	Connector X1.....	61
C.1.3	Connector X20.....	62
C.1.4	X40 connector.....	63
C.1.5	Jumper X2.....	64
C.1.6	Jumper X3.....	64
<b>C.2</b>	<b>R&amp;S TS-PRIO4.....</b>	<b>64</b>
C.2.1	Connector X20.....	64
C.2.2	Rear connector X34.....	65
C.2.3	Jumpers.....	66
<b>C.3</b>	<b>R&amp;S TS-PTR.....</b>	<b>67</b>
C.3.1	X10 connector on the front.....	67
C.3.2	Connector X20.....	69
<b>C.4</b>	<b>R&amp;S TS-PTRF.....</b>	<b>70</b>
C.4.1	X10 connector on the front.....	70
C.4.2	Internal X20 connector.....	72
C.4.3	Internal X33 connector.....	74
C.4.4	Internal X34 connector.....	75
C.4.5	Internal X35 connector.....	75
C.4.6	Internal X36 connector.....	76
C.4.7	Internal X37 connector.....	77
C.4.8	Internal X38 connector.....	77
C.4.9	Internal X39 connector.....	78
C.4.10	Internal X40 connector.....	79
C.4.11	Internal X1 connector.....	79
C.4.12	Internal X2 connector.....	80
C.4.13	Internal X3 connector.....	81

C.4.14	Internal X4 connector.....	81
C.4.15	Internal X5 connector.....	82
C.4.16	Internal X6 connector.....	82
C.4.17	Internal X7 connector.....	83
C.4.18	Internal X8 connector.....	84
C.4.19	Internal X9 connector.....	84
C.4.20	Internal X41 connector.....	85
C.4.21	Internal X42 connector.....	85
C.4.22	Internal X32 connector.....	86
C.4.23	Internal X30 connector.....	86
<b>C.5</b>	<b>R&amp;S TS-PXM1.....</b>	<b>87</b>
C.5.1	X10 connector on the front.....	87
C.5.2	Control: connector X33.....	89
C.5.3	Connectors X34 to X37.....	90

# 1 Safety information (multilingual)

This option or accessory is designed for a specific Rohde & Schwarz product. Multilingual safety information is delivered with the product. Follow the provided installation instructions.

Esta opción o este accesorio están diseñados para un producto Rohde & Schwarz concreto. El producto va acompañado de información de seguridad en varios idiomas. Siga las instrucciones de instalación puestas a disposición.

Diese Option oder dieses Zubehör ist für ein bestimmtes Rohde & Schwarz Produkt vorgesehen. Mit dem Produkt werden mehrsprachige Sicherheitsinformationen geliefert. Befolgen Sie die mitgelieferten Installationsanweisungen.

Cette option ou cet accessoire est conçu pour un produit Rohde & Schwarz spécifique. Des informations de sécurité multilingues sont fournies avec le produit. Suivez les instructions d'installation fournies.

Questa funzione opzionale o accessoria è progettata per un prodotto Rohde & Schwarz specifico. Con il prodotto sono fornite informazioni sulla sicurezza in formato multilingue. Seguire le istruzioni di installazione allegate.

Esta(e) opção ou acessório foi concebida(o) para um produto específico da Rohde & Schwarz. Serão fornecidas informações de segurança multilingues com o produto. Siga as instruções de instalação fornecidas.

Αυτή η προαιρετική επιλογή ή εξάρτημα έχει σχεδιαστεί για συγκεκριμένο προϊόν Rohde & Schwarz. Μαζί με το προϊόν παρέχονται πληροφορίες ασφαλείας σε πολλές γλώσσες. Ακολουθήστε τις παρεχόμενες οδηγίες εγκατάστασης.

Din l-għażla jew aċċessorju huma mfassla għal prodott Rohde & Schwarz speċifiku. L-informazzjoni multilingwi dwar is-sikurezza hija pprovduta mal-prodott. Segwi l-istruzzjonijiet ipprovduti għall-installazzjoni.

Deze optie of dit accessoire is ontwikkeld voor een specifiek product van Rohde & Schwarz. Het product wordt geleverd met veiligheidsinformatie in meerdere talen. Volg de meegeleverde installatie-instructies.

Denne mulighed eller tilbehørsdel er designet til et specifikt Rohde & Schwarz produkt. En flersproget sikkerhedsanvisning leveres sammen med produktet. Følg de medfølgende installationsanvisninger.

Detta tillval eller tillbehör är avsett för en särskild produkt från Rohde & Schwarz. Säkerhetsinformation på flera språk medföljer produkten. Följ de medföljande installationsanvisningarna.

Tämä vaihtoehto tai lisävaruste on suunniteltu tietyille Rohde & Schwarz -yrietyksen tuotteelle. Tuotteen mukana on toimitettu monikieliset turvallisuusohjeet. Noudata annettuja asennusohjeita.

Dette alternativet eller ekstrautstyret er utformet for et spesifikt Rohde & Schwarz produkt. Flerspråklig sikkerhetsinformasjon leveres med produktet. Overhold installasjonsveiledningen som følger med.

See valik või lisaseade on mõeldud konkreetsele Rohde & Schwarz tootele. Tootega on kaasas mitmekeelne ohutusteave. Järgige kaasasolevaid paigaldusjuhiseid.

Ští opcija vai piederums ir izstrādāts īpaši Rohde & Schwarz produktam. Produktam pievienota drošības informācija vairākās valodās. Ievērojiet sniegtos uzstādīšanas norādījumus.

Ši parinktis ar priedas skirti konkrētam Rohde & Schwarz gaminiui. Su gaminiu pateikiama saugos informācijas keliomis kalbomis. Laikykitės pateikiamų montavimo nurodymų.

Þessi auka- eða fylgibúnaður er hannaður fyrir tiltekna Rohde & Schwarz vöru. Öryggisupplýsingar á mörgum tungumálum fylgja með vörunni. Fylgið meðfylgjandi uppsetningarleiðbeiningum.

Tá an rogha nó an oiriúint seo ceaptha le haghaidh táirge Rohde & Schwarz sonrach. Cuirtear eolas sábháilteachta ilteangach ar fáil leis an táirge. Lean na treoracha suiteála a thugtar.

Эта опция или принадлежность предназначена для конкретного продукта Rohde & Schwarz. В комплект поставки продукта входят инструкции по технике безопасности на нескольких языках. Соблюдайте прилагаемые инструкции по установке.

Ця опція або приладдя призначені для конкретного виробу Rohde & Schwarz. Інструкції з техніки безпеки кількома мовами постачаються разом із виробом. Дотримуйтеся наданих інструкцій зі встановлення.

Ta opcja lub akcesorium jest przeznaczona do określonego produktu Rohde & Schwarz. Dostarczany produkt zawiera informacje w wielu językach dotyczące bezpieczeństwa. Należy postępować zgodnie z dostarczonymi instrukcjami instalacji.

Tato varianta nebo příslušenství je určeno pro konkrétní produkt Rohde & Schwarz. S produktem jsou dodávány vícejazyčné bezpečnostní informace. Řiďte se příloženými pokyny k instalaci.

Táto verzia alebo príslušenstvo je navrhnutá pre špecifický výrobok Rohde & Schwarz. S výrobkom sa dodávajú viacjazyčné bezpečnostné pokyny. Riadte sa dodanými pokynmi na inštaláciu.

Ta možnost ali dodatek je zasnovan za določen izdelek podjetja Rohde & Schwarz. Izdelku so priložena varnostna navodila v več jezikih. Upoštevajte priložena navodila za namestitev.

Ezt a beállítást vagy tartozékot egy adott Rohde & Schwarz termékhez tervezték. A termékhez többnyelvű biztonsági információt mellékelünk. Kövesse a mellékelt szerelési utasításokat.

Тази опция или аксесоар са проектирани за специфичен продукт на Rohde & Schwarz. Многоезикова информация за безопасност се доставя с продукта. Следвайте предоставените инструкции за монтаж.

Ova opcija ili oprema namijenjena je za određeni proizvod tvrtke Rohde & Schwarz. Uz proizvod su dostavljene sigurnosne napomene na više jezika. Pratite isporučene upute za ugradnju.



Ova opcija ili pribor je dizajniran za određeni Rohde & Schwarz proizvod. Proizvodu su priložene sigurnosne informacije na više jezika. Slijedite priložena uputstva za instalaciju.

Ova opcija ili dodatni pribor je projektovan za određeni Rohde & Schwarz proizvod. Bezbednosne informacije na više jezika se isporučuju uz proizvod. Sledite dostavljena uputstva za instalaciju.

Această opțiune sau acest accesoriu a fost conceput pentru un produs specific Rohde & Schwarz. Informațiile multilingve privind siguranța sunt livrate împreună cu produsul. Urmați instrucțiunile de instalare furnizate.

Ky opsion ose aksesori është krijuar për një produkt specifik Rohde & Schwarz. Bashkë me produktin jepen edhe informacionet e sigurisë në shumë gjuhë. Ndiqni udhëzimet e dhëna të instalimit.

Оваа опција или додаток се наменети за одреден производ на Rohde & Schwarz. Со производот се испорачани повеќејазични безбедносни упатства. Следете ги дадените упатства за инсталација.

Bu opsiyon veya aksesuar, belirli bir Rohde & Schwarz ürünü için tasarlanmıştır. Çok dilli güvenlik uyarıları ürünle birlikte teslim edilir. Size sağlanan kurulum talimatlarına uyun.

אפשרות זו או האביזר מיועדים למוצר ספציפי של Rohde & Schwarz. מידע רב-לשוני בנושא בטיחות מצורף למוצר. יש לפעול בהתאם להנחיות ההתקנה המצורפות.

تم تصميم هذا الخيار أو الملحق لمنتج معين من منتجات Rohde & Schwarz. يتم تزويد معلومات السلامة متعددة اللغات مع المنتج. اتبع تعليمات التركيب الموضحة.

این قابلیت یا وسیله جانبی منحصراً برای محصول به خصوص Rohde & Schwarz طراحی شده است. اطلاعات ایمنی چندزبانه همراه این دستگاه ارائه شده است. دستورالعمل‌های نصب ارائه شده را دنبال کنید.

اسن اختیار یا حصے کو مخصوص Rohde & Schwarz پروڈکٹ کے لئے تیار کیا گیا ہے۔ پروڈکٹ کے ساتھ کثیر السانی زبانوں میں تحفظ کی معلومات فراہم کی جاتی ہیں۔ فراہم کردہ تنصیب کی ہدایات پر عمل کریں۔

Šu opsiya ýa-da esbap Rohde & Schwarz anyk önüm üçin niýetlenilen. Dürli dildäki howpsuzlyk barada maglumat önüm bilen bile üpjün edilýär. Üpjün edilen gurnama ugrukdymalaryny ýerine ýetiriň.

इस विकल्प या एक्सेसरी को एक विशेष Rohde & Schwarz उत्पाद के लिए डिज़ाइन किया गया है. उत्पाद के साथ बहुभाषी सुरक्षा जानकारी दी जाती है. प्रदान किए गए इंस्टालेशन अनुदेशों का पालन करें.

本选项或附件专门设计用于特定的 Rohde & Schwarz 产品。产品随附多种语言版本的安全资讯。谨遵文件中的安装说明。

本オプションアクセサリは、特定の Rohde & Schwarz 製品向けに設計されています。多言語で記載された安全情報が製品に付属します。付属のインストール手順に従ってください。

이 옵션 또는 액세서리는 특정 Rohde & Schwarz 제품용으로 설계되었습니다. 제품과 함께 다국어로 작성된 안전 정보가 제공됩니다. 함께 제공된 설치 지침을 따르십시오.

本選配或配件專門設計用於特定的 Rohde & Schwarz 產品。產品隨附多種語言版本的安全資訊。遵守文件中的安裝說明。

Tùy chọn hoặc phụ kiện này dành riêng cho một sản phẩm Rohde & Schwarz cụ thể. Thông tin an toàn đa ngôn ngữ được cung cấp kèm theo sản phẩm. Thực hiện theo hướng dẫn lắp đặt kèm theo.

ตัวเลือกหรืออุปกรณ์เสริมนี้ออกแบบมาสำหรับผลิตภัณฑ์ Rohde & Schwarz โดยเฉพาะ โดยจะมีการจัดส่งข้อมูลด้านความปลอดภัยหลายภาษามาให้พร้อมกับผลิตภัณฑ์ ปฏิบัติตามคำแนะนำในการติดตั้งที่ให้ไว้

Pilihan atau aksesoris ini direka bentuk untuk produk Rohde & Schwarz yang tertentu. Maklumat keselamatan berbilang bahasa disertakan bersama produk. Ikut arahan pemasangan yang diberikan.

Opsi atau aksesoris ini dirancang untuk produk Rohde & Schwarz tertentu. Informasi keamanan dalam beberapa bahasa juga disertakan bersama produk. Ikuti petunjuk pemasangan yang disediakan.

Esta opción o este accesorio están diseñados para un producto Rohde & Schwarz en concreto. El producto va acompañado de información de seguridad en varios idiomas. Siga las instrucciones de instalación proporcionadas con el producto.

Esta opção ou acessório foi desenvolvido para um produto Rohde & Schwarz específico. Informações de segurança em vários idiomas acompanham o produto. Siga as instruções de instalação disponibilizadas.

## 2 Documentation overview

This section provides an overview of the R&S TSVP (test system versatile platform) user documentation.

All documents are delivered with the Generic Test Software Library ("R&S GTSL") installation package. After installing the software, you can open all the documentation from the Windows "Start" menu. Additionally, you can find detailed information about the software interfaces in the "R&S GTSL Help" folder in the Windows "Start" menu.

The user documentation and "R&S GTSL" installation package are also available for download in GLORIS at:

<https://gloris.rohde-schwarz.com/>

For details, see the R&S TSVP Getting Started manual.

### 2.1 Getting started manual

Introduces the R&S TSVP (test system versatile platform) and describes how to set up and start working with the product. It includes safety information.

A printed version is delivered with the instrument.

### 2.2 User manuals

Separate manuals are provided for the base units, the individual plug-in module types, as well as for the control software and the calibration tool:

- Base unit manual  
The base unit user manuals introduce the base units and describes how to set up and operate the product. It includes safety information and information on maintenance and instrument interfaces. It includes the contents of the getting started manual.
- Plug-in module manuals  
Contain the description of the specific modules. Basic information on setting up the R&S TSVP (test system versatile platform) is not included.
- In-System calibration user manuals  
Provide all the information required for installation and operation of the in-system calibration R&S TS-ISC solution.
- Control software
  - R&S GTSL  
Generic Test Software Library
  - R&S EGTSL  
Enhanced Generic Test Software Library
  - R&S IC-Check

## Generic Test Software Library

### 2.3 System manual

Describes the complete R&S TSVP (test system versatile platform) as a whole, including the combined use of R&S CompactTSVP and R&S PowerTSVP, plug-in modules and generic test software. It also includes typical use cases.

Additionally, it describes known installation problems (hardware and software) along with possible solutions.

### 2.4 Service manual

Describes the self-test to check correct operation, troubleshooting and fault elimination, and contains mechanical drawings and spare part lists.

### 2.5 Printed safety instructions

Provides safety information in many languages. The printed document is delivered with the product.

### 2.6 Brochures and specifications

Separate brochures are provided for the base unit, the individual plug-in module types, as well as for the control software. The brochures provide an overview of the base units and each additional module, and also contain the technical specifications. They also list the hardware options and their order numbers, and optional accessories.

### 2.7 Release notes and open source acknowledgment

The release notes list new features, improvements and known issues of the current software version. In addition, the available firmware versions and the firmware update procedure for plug-in modules are described.

The open-source acknowledgment document provides verbatim license texts of the used open source software.

## 3 Welcome to the R&S TS-PIO3B

The present operating instructions provide all the information required for installing, programming and operating the following modules in the R&S TSVP Test System Versatile Platform:

- Digital I/O Module R&S TS-PIO3B
- Signal Transmission Module R&S TS-PTR
- Port Transmission Module R&S TS-PTRF
- Rear Transmission Module R&S TS-PRIO4
- Switching Extension Module R&S TS-PXM1

The following list summarizes the properties and interdependencies:

### Digital I/O Module R&S TS-PIO3B

- **Variant 02 (1512.4407.02)**  
64 "quasi-bidirectional" open drain I/O channels, all available on the front panel, 24 of these channels are also routed to the backplane.
- **Variant 04 (1512.4407.04)**  
40 "quasi-bidirectional" open drain I/O channels, all available on the front panel, 24 passive lines between X20 and X10.
- 8 digital I/O ports of 8 bit each, open drain outputs
- 1 digital I/O port, 8 bit, TTL signal level
- 8 analogue inputs, 0-5 V, resolution of 10 bits
- Maximum current of the open drain channels 200 mA
- +5 V / 2 A and +12 V / 2 A fused available on the front connector
- Soft panel for interactive operation
- LabWindows/CVI driver available
- External SPI interface, e.g. for adapter identification
- controlled via the CAN bus
- Can be used in the backplane extension R&S TS-PXB2 (slots A1 and A2) or in any other CAN bus slot.
- Standard CompactPCI card format, reaches the front panel of the base unit only in connection with R&S TS-PTRF

### Signal Transmission Module R&S TS-PTR

- Feedthrough of 24 signal lines from the rear panel to the front panel
- Requires R&S TS-PRIO4 or R&S TS-PXB2.
- Standard CompactPCI card format, reaches the front panel of the base unit only in connection with R&S TS-PTRF
- +5 V / 2 A and +12 V / 2 A fused on the front connector (X10) available

### Port Transmission Module R&S TS-PTRF

- Adapter module for connection to R&S TS-PIO3B or R&S TS-PTR

- As many as 8 modules R&S TS-PXM... (e.g. R&S TS-PXM1) can be connected (X33 to X40)
- Optional (configurable via jumpers X33 to X40) feedthrough of all 8 open drain ports (64 bits) from the R&S TS-PIO3B
- Optional (configurable via jumpers X4) feedthrough of the 8 analogue lines of the R&S TS-PIO3B
- Optional (configurable via jumpers X42) external use of the SPI bus of the R&S TS-PIO3B, generation of up to 8 SPI Chip Select signals (configurable via jumpers X41).
- External +5 V, +12 V
- Requires R&S TS-PIO3B or R&S TS-PTR

#### **Rear Transmission Module R&S TS-PRIO4**

- Routing of three 8-bit ports of the R&S TS-PIO3B to the TSVP rear panel.
- Requires R&S TS-PIO3B or R&S TS-PTR

#### **Switching Extension Module R&S TS-PXM1**

- 32 switches, arranged in 8 groups of 4 switches each (8 x 4PDT)
- Contact load capacity 2 A / 30 V DC
- Control via R&S TS-PIO3B and R&S TS-PTRF
- LEDs for status display
- Requires R&S TS-PIO3B and R&S TS-PTRF

[Figure 3-1](#) shows various installation variants of the modules in a TSVP.

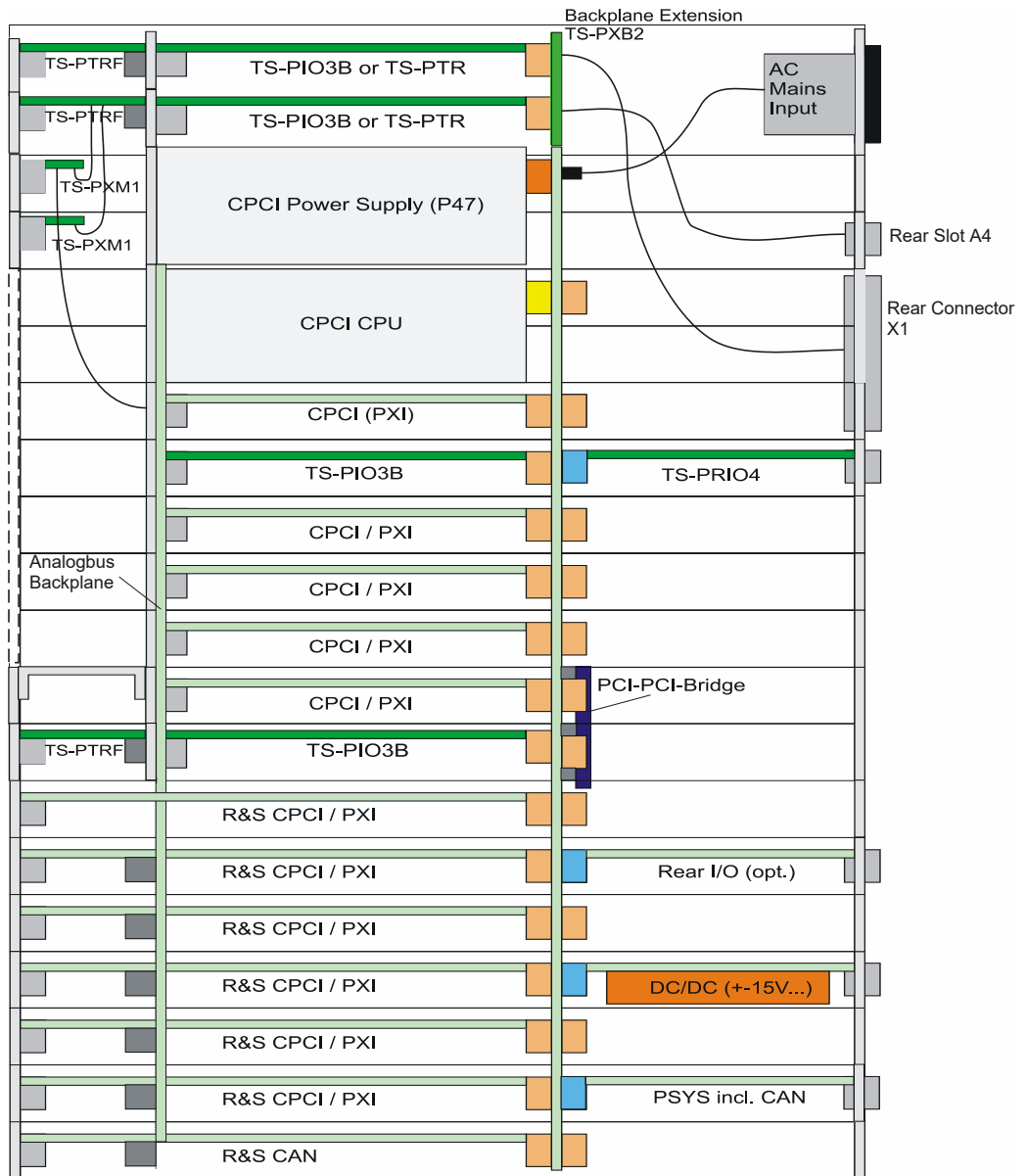

Figure 3-1: Example configuration of the modules in an R&S TSVP

## 4 Module tour

This chapter contains functional descriptions of the modules.

### 4.1 R&S TS-PIO3B

The Digital I/O Module R&S TS-PIO3B is a plug-in card for CAN slots of the R&S TSVP frames. The module provides digital, quasi-bidirectional lines, a TTL port, analog inputs, SPI signals and supply voltages. All the I/O signals are referenced to earth.

The module is equipped with a separate processor and is controlled via the CAN bus. The module is available in 2 variants (see "[Digital I/O Module R&S TS-PIO3B](#)" on page 13).

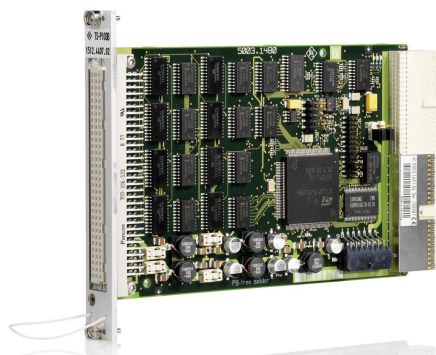

*Figure 4-1: View of the Digital I/O Module R&S TS-PIO3B*

For a detailed block diagram of the module, see [Chapter B.1, "R&S TS-PIO3B"](#), on page 51.

#### 4.1.1 Open drain I/O ports

Ports 0 – 7 (variant 02) and ports 0 – 4 (variant 04) have a width of 8 bits each and are wired at the pin as follows:



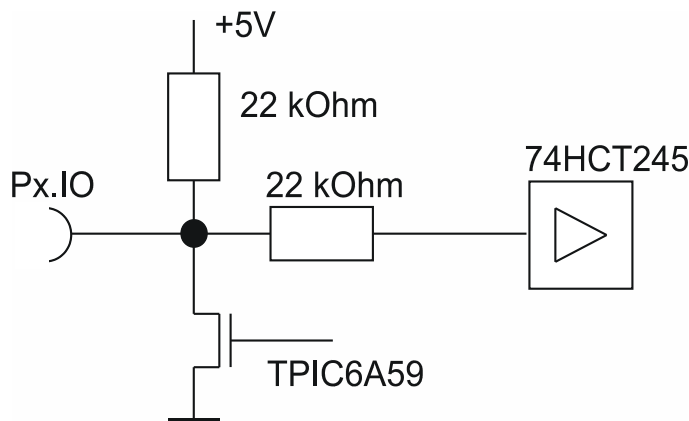

Figure 4-2: Wiring of the open drain I/O ports

The FET shown is integrated into a Texas Instruments TPIC6A595 chip.

This wiring permits a quasi bidirectional use. A ‚high‘ level is generated via a 22 kOhm resistor at +5 V and can be pulled to ‚low‘ by an external source.

To switch the pin to input, the port bit is set to ‚1‘. In this way, the FET driver switches off and the ‚high‘ level on the pin is generated by the 22 kOhm pull-up resistor. Thus, the external source must sink at least 190  $\mu\text{A}$  to be recognized reliably as ‚low‘. This corresponds to an external resistor of maximally 4.2 kOhm.

As an output, the circuit can only drive a ‚low‘ level actively. For this purpose, the corresponding bit is set to ‚0‘ in the SW. The FET then switches to a low resistance (typ. 1 Ohm) and current flows through an external load against a positive voltage. A typical application is the switching of a relay, for example, as shown in the application examples (refer to 7.1: Control of Relays / Pneumatic Valves / Vacuum Valves).

The following function call writes an open drain I/O port:

```
ViStatus rspio3b_SetPort (
ViSession instrumentHandle,
ViInt32 port,
ViUInt8 mask,
ViUInt8 pattern);
```

The following function call reads an open drain I/O port:

```
ViStatus rspio3b_ReadPort (
ViSession instrumentHandle,
ViInt32 port,
ViPUInt8 pattern);
```

Ports 5, 6 and 7 are not only available at X10 on the front but at the same time at X20 and thus connected to the backplane. Via the R&S TS-PXB2 or R&S TS-PRIO4 options, these ports can be routed to the rear panel of the R&S CompactTSVP or R&S PowerTSVP.

For variant 04 (1512.4407.04), the lines of these ports are passive and can be used to feed trough signals.

Alternatively, you can use the FET switch with the aid of the Signal routing library (see [Chapter 7.3.2, "Programming with signal routing library"](#), on page 41). Since you have to take into account the switch times of the controlled relays in the application, use the switch settings in the configuration file:

```
Application.ini
-----
[bench->rspio3bRoute]
SwitchSettings      = switch->test

[switch->test]
; connect command with 10 ms settling time
#CONNECT = PIO3B!P1IO0 > PIO3B!GND, ?10

Source Code
-----
ROUTE_Execute (0, residRoute, "#CONNECT",
              &errorOccurred, &errorCode, errorMessage);
```

#### 4.1.2 TTL port

Port 9 is a digital I/O port with the following wiring per I/O pin:

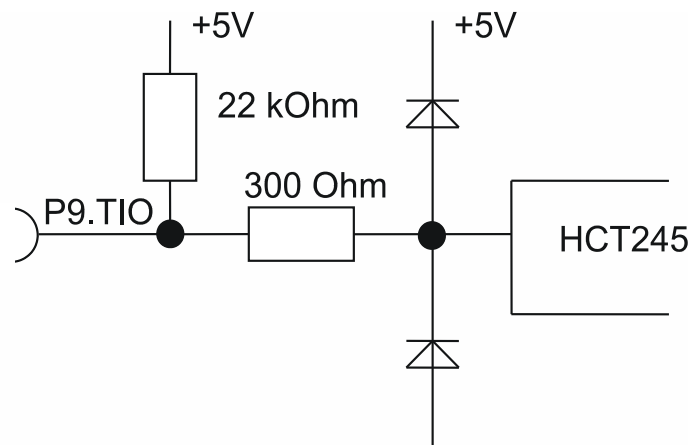

**Figure 4-3: Wiring of I/O port 9**

The direction of port 9 can be switched for all port bits together.

If an R&S TS-PTRF is plugged into X10, port 9 is no longer available. In this case, port 9 is used internally for generating various signals for controlling the R&S TS-PTRF.

The following function call writes port 9 (in this case, the parameter port must be set to RSPIO3B\_DIG\_PORT\_9):

```
ViStatus rspio3b_SetPort (
ViSession instrumentHandle,
ViInt32 port,
ViUInt8 mask,
ViUInt8 pattern);
```

The following function call reads port 9 (in this case, the parameter port must be set to RSPIO3B\_DIG\_PORT\_9) :

```
ViStatus rspio3b_ReadPort (
ViSession instrumentHandle,
ViInt32 port,
ViPUInt8 pattern);
```

The following function call switches the direction of port 9:

```
ViStatus rspio3b_SetPortTioOutput (
ViSession instrumentHandle,
ViBoolean outputFlag);
```

### 4.1.3 Analog inputs

The analog inputs are wired as follows:

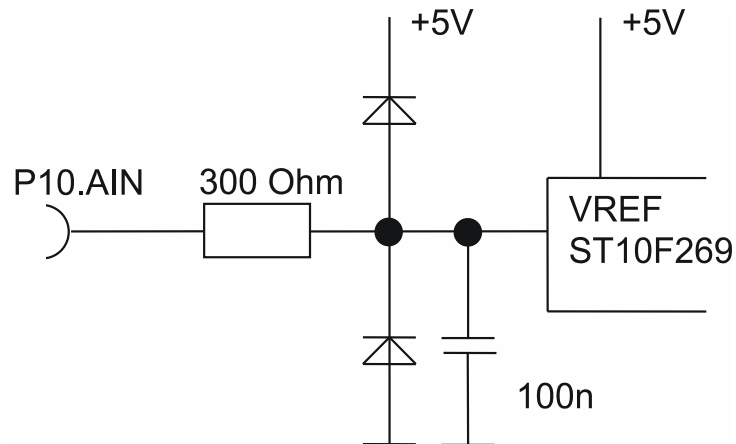

**Figure 4-4: Wiring of the analog inputs**

Following the protective circuit, the analog port is routed directly to the ST10 processor. The reference voltage is directly the supply voltage from the backplane and thus relatively imprecise.

Thus, the analog port can be used for simple measurement tasks. For increased accuracy demands or measurement speeds, further TSVP modules (R&S TS-PSAM, R&S TS-PIO2, R&S TS-PAM) are available.

The following function call reads the analog voltage at a port pin:

```
ViStatus rspio3b_ReadADC (
ViSession instrumentHandle,
ViInt32 channel,
ViPReal64 pVoltage);
```

#### 4.1.4 SPI

The SPI interface integrated in the ST10 processor is used internally for controlling ports P0 – P7. However, it is also available at X10 and can thus be used freely – with external additional wiring.

All write accesses to ports P0 – P7 cause parallel activity on the external lines SCLK and MOSI. To select external modules and not respond to these internal accesses, these modules must receive a Chip Select signal. This can be achieved through a P9 port bit, for example.

The internal ports P0-P7 do not respond to an external SPI access.

The SPI port is hardcoded to  $CPOL=0$ ,  $CPHA=0$  (SPI mode 0). Data are output on MOSI with the falling SCLK edge and MISO is read with the rising SCLK edge.

In idle mode, SCLK is on 'low', the MSB is sent or read in first. The [Figure 4-5](#) shows an 8-bit SPI transfer, output of the value 0x51 on MOSI. The example signal applied to MISO is read in as 0x69.

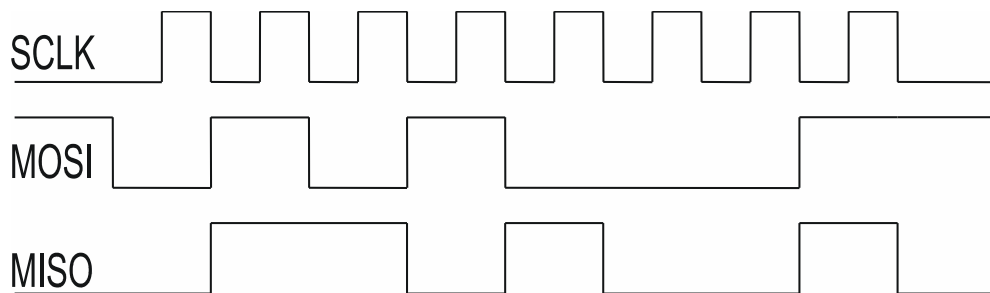

**Figure 4-5: Basic SPI cycle (8 bits)**

When a R&S TS-PTRF is connected to a R&S TS-PIO3B, the generation of an external Chip Select signal for SPI accesses is handled by the R&S TS-PTRF. This functionality is described in [Chapter 6, "Typical applications"](#), on page 35.

The following function performs an SPI transfer:

```
ViStatus rspio3b_SpiTransfer (
ViSession instrumentHandle,
ViChar *pTxBuffer,
ViChar _VI_FAR pRxBuffer[],
ViInt32 ByteCount);
```

The following function selects the port, for which a ChipSelect is to be generated:

```
ViStatus rspio3b_PtrfSelectPort (
ViSession instrumentHandle,
ViInt32 port);
```

#### 4.1.5 Voltage sources

The R&S TS-PIO3B module provides +5 V and +12 V on X10. The voltages are fused through SMD slow-blowing fuses with a nominal value of 2 A /.

To change the fuses, see [Chapter 8.1, "Changing fuses"](#), on page 46.

The voltages are led from the frame's backplane to the connector X10 on the front via fuses F1 and F4. The following tables show the signals' paths.

**Table 4-1: Fuse F1**

Signal on the backplane		Fuse	Signal on the X10 connector on the front	
X1.D1 X20.E2	+12V_IN	F1	X10.C30 X10.B31	+12V

**Table 4-2: Fuse F4**

Signal on the backplane		Fuse	Signal on the X10 connector on the front	
X1 X20	+5V_IN	F4	X10.C29 X10.B30	+5V

The signals going through the fuses F2 and F3 can be configured via jumpers on X2 and X3.

**Table 4-3: Fuse F2**

Signal on the backplane		Jumper X3		Fuse	Signal on the X10 connector on the front	
X20.E19 X20.B20	AUX1	X3.1	X3.2	F2	X10.C27 X10.B28	AUX1
X1	3,3V_IN	X3.3				



X1 and therefore 3,3V is not available on the backplane extension R&S TS-PXB2 and R&S Power TSVP.

**Table 4-4: Fuse F3**

Signal on the backplane		Jumper X2		Fuse	Signal on the X10 connector on the front	
X20.D19 X20.A20	AUX2	X2.1	X2.2	F3	X10.C28 X10.B29	AUX2
X1.B1 X20.A19	-12V_IN	X2.3				

[Figure 4-6](#) shows the jumpers' position and default settings.

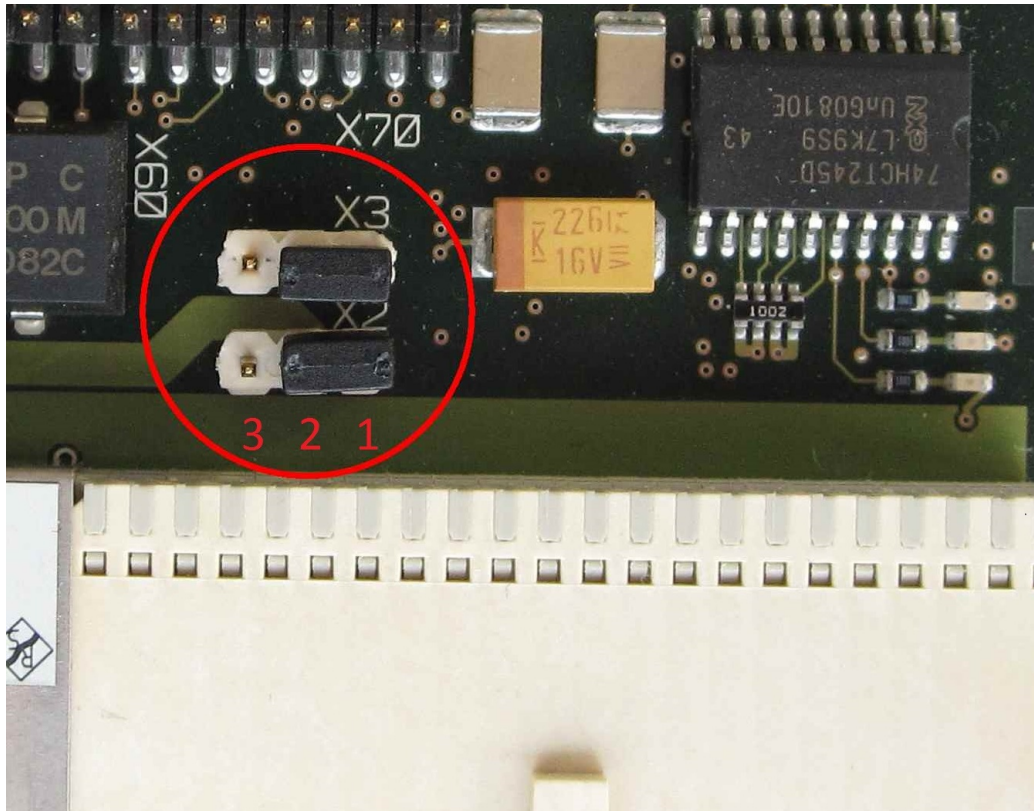

Figure 4-6: Default jumper settings X2, X3



If the jumper settings change, for example, if feeding the signals AUX1 and AUX2, the self-test has to be configured. In that way, errors are avoided.

See [Chapter 9.2.2, "Fuse test"](#), on page 48 and the "Self Test of Plug-In Cards" chapter in the R&S TSVP service manual.

Figure 4-7 shows the position of the fuses.

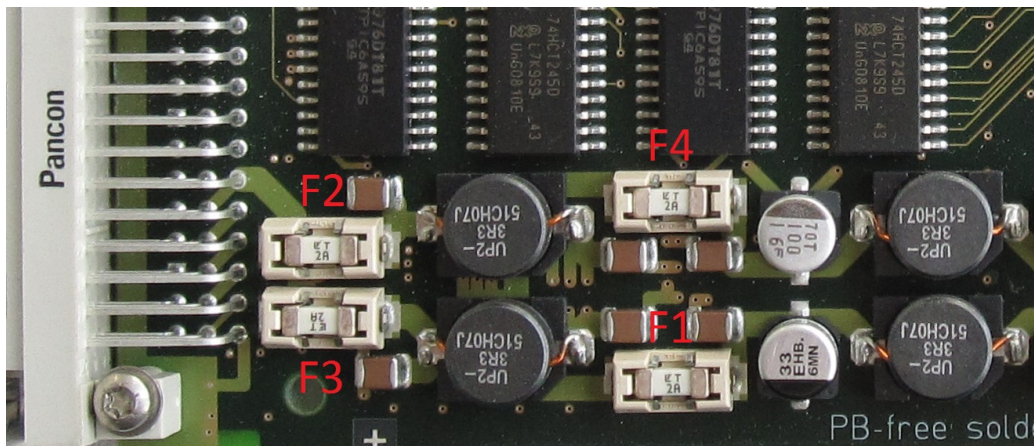

Figure 4-7: Position of fuses

### 4.1.6 Other interface signals

**CFG\_AIN, AUX1, AUX2:** Do not connect anything to these signals. They are for internal use.

**CHA\_GND:** Chassis Ground: This pin is connected to the chassis earth.

**GND:** Signal earth: These pins are connected to the digital earth. When a device under test is connected, the DUT GND must be connected to GND. To avoid ground loops, do not connect GND and CHA\_GND.

**INH:** dedicated output signal, for free use.

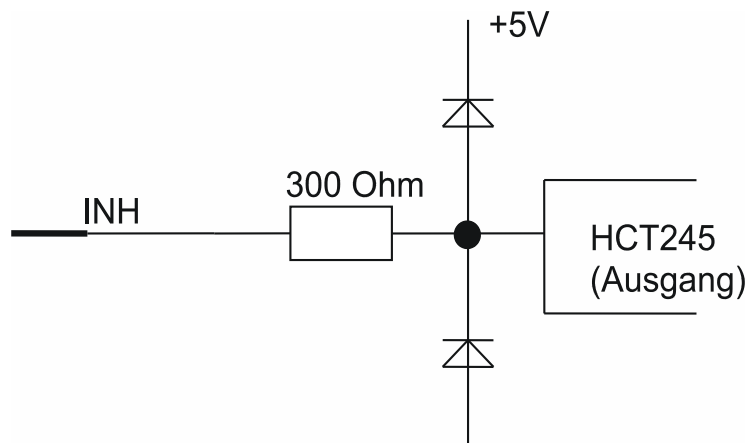

*Figure 4-8: Wiring of the INH signal*

The INH signal can be checked using the following function:

```
ViStatus rspio3b_SetInhibit (
ViSession instrumentHandle,
ViBoolean highFlag);
```

## 4.2 R&S TS-PRIO4

The Rear Transmission Module R&S TS-PRIO4 is a passive adapter module for the rear I/O range for routing signals from a Digital I/O Module R&S TS-PIO3B or a Signal Transmission Module R&S TS-PTR to the rear panel of the R&S TSVP frame.





Figure 4-9: View of the R&S TS-PRIO4

For a detailed block diagram of the module, see [Chapter B.2, "R&S TS-PRIO4"](#), on page 52.

#### 4.2.1 Status LEDs

The LEDs available on the R&S TS-PRIO4 module are not used in the present application.

#### 4.2.2 Passive wiring

The Rear Transmission Module R&S TS-PRIO4 routes 24 lines passively from the backplane (X20) to the rear panel (X30).

### 4.3 R&S TS-PTR

The Signal Transmission Module R&S TS-PTR is a passive adapter module for routing signals through the R&S TSVP. The module is mechanically compatible to the Digital I/O Module R&S TS-PIO3B.



To route the signals to the rear panel, for installation in slots A1 and A2, a R&S TS-PXB2 backplane extension and for installation in slots 3-14 a Rear Transmission Module R&S TS-PRIO4 is additionally required.

To route the signals to the front panel of the R&S TSVP frame, a Port Transmission Module R&S TS-PTRF is required.

[Figure 3-1](#) shows various installation options.

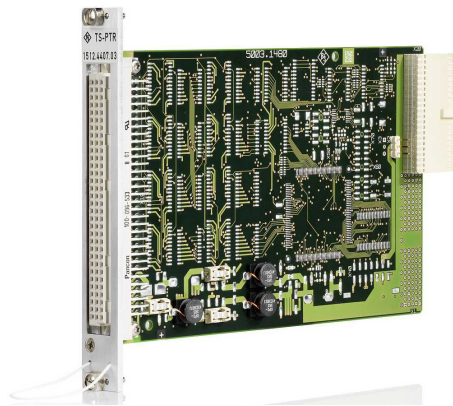

*Figure 4-10: View of the R&S TS-PTR module*

For a detailed block diagram of the module, see [Chapter B.3, "R&S TS-PTR"](#), on page 52.

### 4.3.1 Passive wiring

The Signal Transmission Module R&S TS-PTR routes 24 lines passively from X20 to X10. The pin assignment is described in [Chapter C.3, "R&S TS-PTR"](#), on page 67.

### 4.3.2 Voltage sources

The R&S TS-PTR module provides +5 V and +12 V on X10. The voltages are fused through SMD slow-blowing fuses with a nominal value of 2 A.

To change the fuses, see [Chapter 8.1, "Changing fuses"](#), on page 46.

## 4.4 R&S TS-PTRF

The Port Transmission Module R&S TS-PTRF is a ranging and distribution module and is connected on the upstream side of a digital I/O module R&S TS-PIO3B or a Signal Transmission Module R&S TS-PTR. The Port Transmission Module R&S TS-PTRF wires the 8 open drain I/O ports of the Digital I/O Module R&S TS-PIO3B to connectors, to which relay modules (e.g. R&S TS-PXM1) can be connected. In addition, the module generates SPI Chip Select signals for external SPI components or SPI components on the relay module.

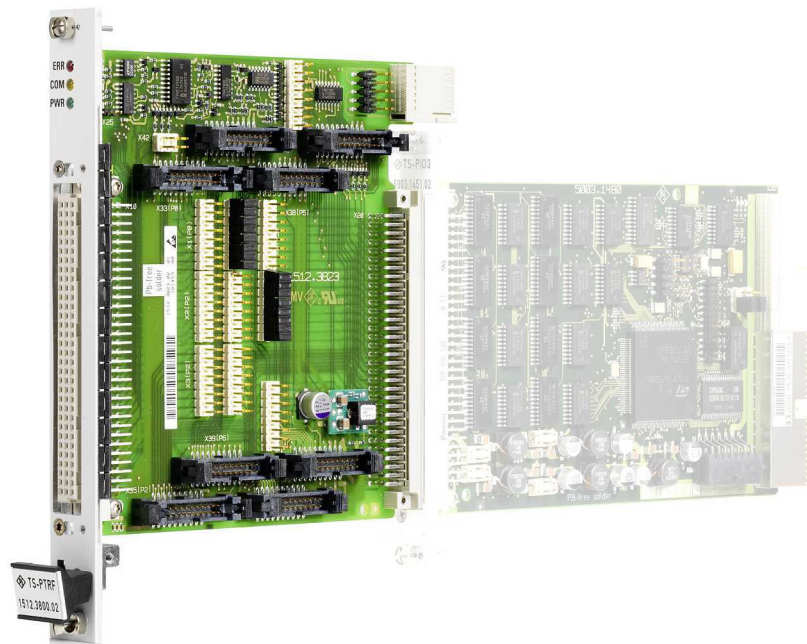

Figure 4-11: View of the R&S TS-PTRF module (with R&S TS-PIO3B)

For a detailed block diagram of the module, see [Chapter B.4, "R&S TS-PTRF"](#), on page 54.

#### 4.4.1 Status LEDs

There are three LEDs on the front of the Port Transmission Module R&S TS-PTRF. These LEDs indicate the actual status of the R&S TS-PIO3B connected to the R&S TS-PTRF. Description of the LEDs:

Table 4-5: Indicators of the R&S TS-PTRF

LED	Description
red	<p>Error status:</p> <p>Lights up for checking purposes for approx. 3 s upon startup or when the R&amp;S TS-PIO3B has detected an error. If the LED glows weakly, the microcontroller of the R&amp;S TS-PIO3B is in the reset state.</p>
yellow	<p>Communication:</p> <p>Lights up for checking purposes for approx. 3 s upon startup or when the R&amp;S TS-PIO3B has received a command from the host that performs an SPI transfer.</p>
green	<p>Supply voltage OK:</p> <p>Lights up when all the supply voltages are applied.</p>

If the R&S TS-PTRF is operated on the R&S TS-PTR, all the LEDs will remain off.

#### 4.4.2 Wiring of the open drain I/O ports and the analogue inputs of the R&S TS-PIO3B

The Port Transmission Module R&S TS-PTRF contacts each of the open drain I/O ports (0-7) of the connected R&S TS-PIO3B to exactly one of the connectors X33 to X40. In addition, each of the open drain I/O ports of the R&S TS-PIO3B can optionally be wired to the front panel via jumpers.

The 8 analogue inputs of the R&S TS-PIO3B can optionally be wired to the front panel via jumpers. In addition, each of the analogue lines is connected to exactly one of the X33 to X40 connectors.

If a module is connected to X33 to X40, the corresponding port should not be used externally.

Figure 4-12 shows this basic wiring.

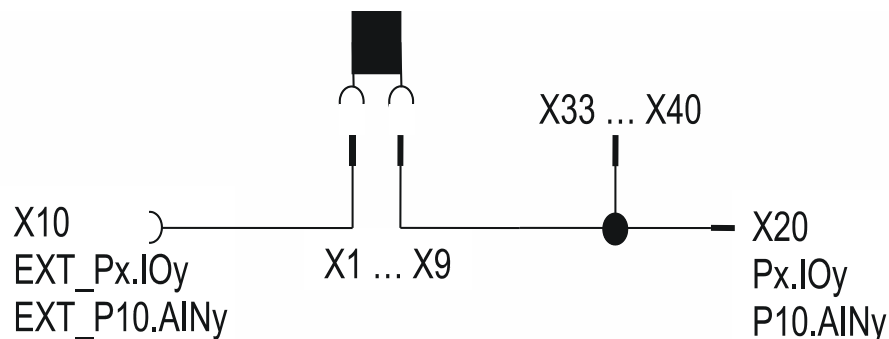

Figure 4-12: Wiring of the R&S TS-PIO3B ports P0 – P7 and P10

The assignment according to Table 4-6 applies:

Table 4-6: Wiring of the 8 bit ports of the R&S TS-PIO3B on the R&S TS-PTRF ( $x = 0..7$ )

R&S TS-PIO3B Port	R&S TS-PTRF X20	R&S TS-PTRF connector	Jumpers to the front panel
P0.IOx	EXT_P0.IOx	X33	X1
P1.IOx	EXT_P1.IOx	X34	X2
P2.IOx	EXT_P2.IOx	X35	X3
P3.IOx	EXT_P3.IOx	X36	X8
P4.IOx	EXT_P4.IOx	X37	X9
P5.IOx	EXT_P5.IOx	X38	X5
P6.IOx	EXT_P6.IOx	X39	X6
P7.IOx	EXT_P7.IOx	X40	X7
P10.AINx	EXT_P10.AINx	X33-X40 (*)	X4

(\*) P10.AIN0 = X33, usw ... P10.AIN7 = X40

As can be seen in [Figure 4-12](#), the R&S TS-PTRF features a jumper to the front panel for each bit of an open drain I/O port or of the analogue port of the R&S TS-PIO3B. If a complete port is to be wired to the front panel, 8 jumpers must be plugged.

The pin assignment according to [Table 4-7](#) applies to each of these ports:

**Table 4-7: Connector pin assignment for ports of the R&S TS-PIO3B on the R&S TS-PTRF**

Bit	pins to be bridged (X33 – X40)
0	1-2
1	3-4
2	5-6
3	7-8
4	9-10
5	11-12
6	13-14
7	15-16

### 4.4.3 Function of port P9.TIO of the R&S TS-PIO3B

If a R&S TS-PTRF is plugged onto a R&S TS-PIO3B, the R&S TS-PIO3B will recognize the R&S TS-PTRF upon booting and will use P9.TIO to control various functions on the R&S TS-PTRF. Thus, the P9.TIO can no longer be used. For this reason, P9.TIO is not available on any R&S TS-PTRF connector.

### 4.4.4 SPI

The R&S TS-PTRF contains logic components for buffering and generating the Chip Select signals for externally and internally connected SPI modules (to connectors X33 – X40). The CS signals are low active, the R&S TS-PTRF features a 10-kOhm pull-up resistor to +5 V.

The SPI signals SCLK, MOSI and MISO of the R&S TS-PIO3B are buffered and routed to connectors X33 to X40 and to the connected relay modules. In addition, the SPI signals SCLK, MOSI and MISO can be routed to the front panel (X10) via jumpers X41 and X42.

The R&S TS-PTRF generates eight SPI Chip Select signals (low active) from the R&S TS-PIO3B port P9.TIO. One CS signal each is wired to X33 to X40 and can be routed in parallel to the front panel (X10) via a jumper.

[Figure 4-13](#) shows a simplified diagram of the wiring:

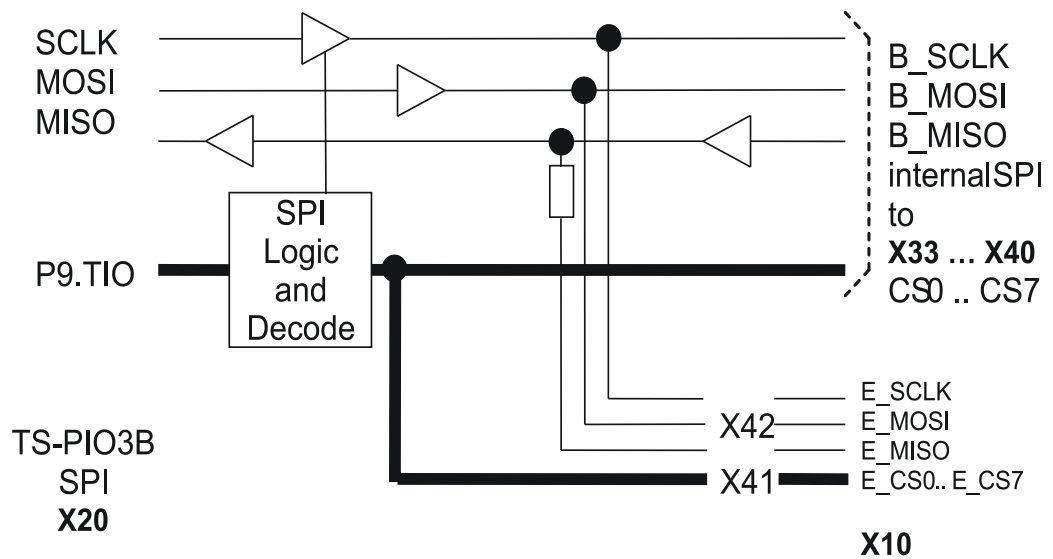

Figure 4-13: Simplified diagram of the SPI

From this wiring and the internal logics of the R&S TS-PIO3B follows:

- To be able to connect an SPI module externally, all the X42 jumpers and one Chip-Select (one jumper on X41) must be plugged.
- If a (relay) module is connected to X33 to X40, the corresponding external CS should not be used.
- The relay drivers available locally on the R&S TS-PIO3B are connected to the same SPI bus. When writing to these relay drivers, the CS corresponding to the port and the E\_CS will be enabled (if the jumper is plugged) but E\_SCLK will not be generated.
- Each SPI access of the R&S TS-PIO3B, internally as well as externally, is signalled by the yellow LED of the R&S TS-PTRF.

#### 4.4.5 +5 V / +12 V voltages

The R&S TS-PTRF receives +12-V supply voltage from the R&S TS-PIO3B or the R&S TS-PTR. This supply voltage is converted to +5 V locally on the R&S TS-PTRF. These +5 V are available externally and to all the ports P0-P7 at connectors X33 to X40. (Relay) modules connected to these connectors (e.g. R&S TS-PXM1) may be supplied by these +5 V (refer to the datasheet of the module), which reduces the current available to external loads accordingly. The 5-V converter can deliver a max. output current of 2 A.

The +12 V are fused on the R&S TS-PIO3B / R&S TS-PTR by fuses. The +5 V generated locally are not fused.

#### 4.4.6 Analogue bus access

The R&S TS-PTRF features a connector to the analogue bus. The 8 lines of the analogue bus are routed to connector X32.

### 4.5 R&S TS-PXM1

The Switching Extension Module R&S TS-PXM1 is a relay module with a total of 32 switches arranged in 8 groups of 4 switches each. Control is implemented via a Port Transmission Module R&S TS-PTRF and a Digital I/O Module R&S TS-PIO3B. All the switching contacts are available on the X10 front connector, the common contacts of the switches are additionally available on connectors.

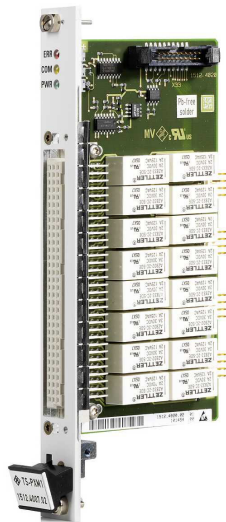

Figure 4-14: View of the R&S TS-PXM1 module

For a detailed block diagram of the module, see [Chapter B.5, "R&S TS-PXM1"](#), on page 56.

#### 4.5.1 Status LEDs

There are three LEDs on the front of the R&S TS-PXM1 module. These LEDs indicate the topical status of the module. Description of the LEDs:

**Table 4-8: Indicators on the R&S TS-PXM1 module**

LED	Description
red	Without function: Lights up for approx. 1 second upon switch-on (for reasons of compatibility to other modules)
yellow	Communication: Lights up briefly when a relay is switched or upon access to the EEPROM.
green	Supply voltage OK: Lights up when all the supply voltages are applied.

## 4.5.2 Relay wiring

The R&S TS-PXM1 module comprises 16 relays with two switches each. Two relays are always served by one control bit, which results in one 4-pin switch per bit (4PDT).

Each relay contact is routed to the front panel X10, the common connection of the switches is also routed to the internal connector. The wiring is listed in [Table 4-9](#) and [Table 4-10](#) (also refer to R&S TS-PXM1).

At the VG connector the wiring is always as follows:

**Table 4-9: Wiring of the VG connector**

Reihe	A	B	C
n(1-32)	X(34-37)_(1-8)_NC	X(34-37)_(1-8)	X(34-37)_(1-8)_NO

- \_NC: normally closed: normally closed state.
- \_NO: normally open: normally open state.
- Control bit = 1: Relay is in normal state, the switch is connected to \_NC
- Control bit = 0: Relay is energized, the switch is connected to \_NO

**Table 4-10: Relay wiring**

Control bit	Relay	Connector	VG96 row
0	K1 und K2	X34.1, X34.2, X34.3, X34.4	1,2,3,4
1	K3 und K4	X34.5, X34.6, X34.7, X34.8	5,6,7,8
2	K5 und K6	X35.1, X35.2, X35.3, X35.4	9,10,11,12
3	K7 und K8	X35.5, X35.6, X35.7, X35.8	13,14,15,16
4	K9 und K10	X36.1, X36.2, X36.3, X36.4	17,18,19,20
5	K11 und K12	X36.5, X36.6, X36.7, X36.8	21,22,23,24

Control bit	Relay	Connector	VG96 row
6	K13 und K14	X37.1, X37.2, X37.3, X37.4	25,26,27,28
7	K15 und K16	X37.5, X37.6, X37.7, X37.8	29,30,31,32



## 5 Installation

1. For R&S TS-PIO3B or R&S TS-PTR:  
Install the module on the front panel as described in the user manuals of the base units.
2. For R&S TS-PRIO4:  
Install the module on the matching rear panel slot as described in the user manuals of the base units.
3. **WARNING!** Risk of electric shock. The test environment, e.g the UUT or additional power supplies, can supply high voltages to the instruments. In this case, the voltage can also apply to the signal output connectors of the R&S TSVP, in particular the analog bus connector X2.  
Therefore, do not connect or disconnect devices from the X2 connectors while connected to an external power supply or UUT.  
  
Always connect both ends of the cable connecting the R&S CompactTSVP and R&S PowerTSVP. Thus, you avoid the risk of touching the X2 connector with a possibly hazardous voltage applied.  
  
Take the system into operation as described in the user manuals of the base units.

### Removing the R&S TS-PIO3B or R&S TS-PTR modules

1. Remove the screws at the top and bottom of the front panel of the R&S TS-PIO3B or R&S TS-PTR module.
2. To remove the R&S TS-PIO3B in particular, use a tool like pliers or a hook to pull the cord.  
The R&S TS-PIO3B module is plugged especially tightly into slots 3 to 14 of the CompactTSVP. To prevent injuries during removal, it is recommended to wear protective gloves. Apply force carefully and do not jerk the module to pull it out.

### Installing the R&S TS-PTRF

1. Shut down and switch off the R&S TSVP base unit.
2. Push the R&S TS-PTRF module into the corresponding R&S TS-PIO3B or R&S TS-PTR module using moderate force.  
Make sure that the removal cord of the R&S TS-PIO3B or R&S TS-PTR is not between the connectors.
3. Make sure the R&S TS-PTRF module is exactly aligned during installation as guide rails are not provided in the front area.  
The R&S TS-PTRF module has been inserted properly when a definite stop can be felt.
4. Tighten the upper and lower screws on the front panel of the R&S TS-PTRF module.

**Installing the R&S TS-PXM1**

To install the module, select an appropriate slot on the front.

1. Shut down and switch off the R&S TSVP base unit.
2. Plug the cable into the R&S TS-PXM1 and into the selected port of the R&S TS-PTRF.
3. Tighten the upper and lower screws on the front panel of the R&S TS-PXM1 module.

## 6 Typical applications

### 6.1 Control of relays / pneumatic valves / vacuum valves

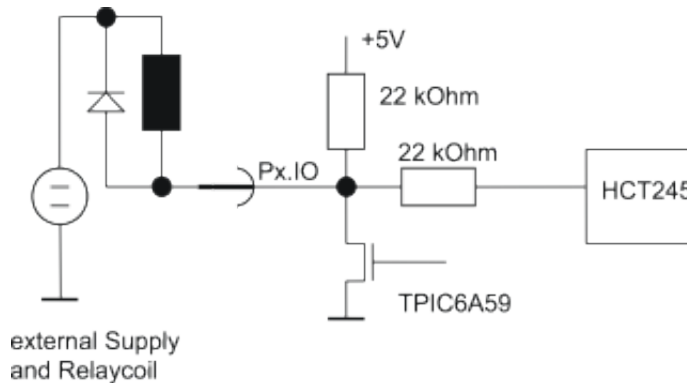

Figure 6-1: Controlling inductive loads with R&S TS-PIO3B (example)

This example shows the control of a relay or inductive valve. The driver stage of an R&S TS-PIO3B and a coil with freewheeling diode are shown.

The externally applied voltage may be up to 30 V.



Due to the 'open drain' design, with external voltages of > 5 V with the port bit = 'high' (switched-off state), a current will flow from the external source through the external load and through the 22 kOhm resistors into the local 5 V supply. With 24 V, this current is approx. 1 mA (depending on the external load).

Also take into consideration that with external voltages of < 5 V with the port bit = 'high' a current will flow from the R&S TS-PIO3B into the external circuit.

### 6.2 Adapter identification

The ports of the R&S TS-PIO3B may be used, e.g. to detect an externally connected test adapter. Two different options are shown in this context.

To be flush with the front panel of the R&S TSVP frame, an R&S TS-PTRF is required for the adapter identification. The jumpers in the R&S TS-PTRF must be configured accordingly (refer to [Chapter 4.4, "R&S TS-PTRF"](#), on page 25).

#### 6.2.1 Parallel adapter identification via ports

The parallel adapter identification is especially easy to implement but requires one or two complete 8 bit I/O ports.

To be able to identify an adapter uniquely, it is only necessary to connect wires in the adapter with GND. Port bits that have not been wired are read as „high“ by the internal pull-up resistors. The ports will then be read in via the following function, thus implementing the adapter identification.

```
ViStatus rspio3b_ReadPort (
ViSession instrumentHandle,
ViInt32 port,
ViPUInt8 pattern);
```

If two ports are used, more than 65000 combinations can be set. This is sufficient to code an adapter identification and an adapter version.

### 6.2.2 Serial adapter identification via SPI-EEPROM

The serial adapter identification uses an SPI-EEPROM in the adapter and can be set up easily in connection with an R&S TS-PTRF. The Atmel AT25160 module is cut out for this purpose, a 16 kbit (2 kbyte) EEPROM for SPI. In this way, all the I/O ports remain free, only one SPI Chip Select signal of the R&S TS-PTRF is occupied.

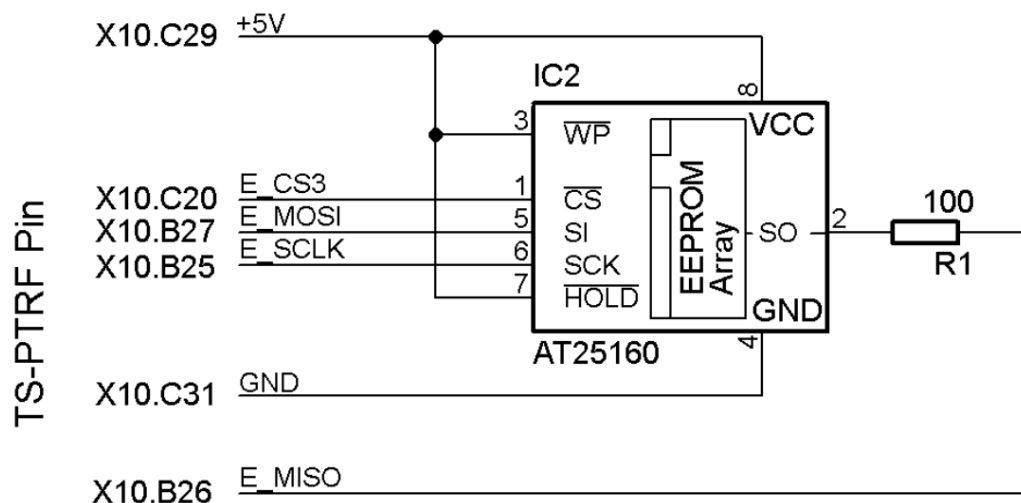

Figure 6-2: System drawing of ATMEL AT25160

The EEPROM is written to and read using the following command.

```
rspio3b_SpiTransfer (...)
```

A simple protocol is required for this purpose (refer to the datasheet of the EEPROM used).

The ChipSelect (in this example E\_CS3) is generated using the following command (only if the EEPROM is connected to an R&S TS-PTRF).

```
rspio3b_PtrfSelectPort (...)
```

Very different types of EEPROMs can be used. Due to its universal software, the R&S TS-PIO3B can serve all the SPI EEPROMs that can handle SPI mode 0.

## 7 Software

### 7.1 Driver software

An IVI-C driver is available for the functions of the R&S TS-PIO3B digital I/O module. The driver is part of the ROHDE & SCHWARZ GTSL software. All the functions of the driver are documented comprehensively in the online Help and in the LabWindows/CVI Function Panels.

During driver installation, the following software modules are installed:

**Table 7-1: Driver installation R&S TS-PIO3B**

Module	Path	Comment
rspio3b.dll	<GTSL directory>\Bin	Driver
rspio3b.chm	<GTSL directory>\Bin	Help files
rspio3b.fpl	<GTSL directory>\Bin	LabWindows CVI Function Panel file, function panels for CVI development interface
rspio3b.sub	<GTSL directory>\Bin	LabWindows CVI attribute file. This file is required by some „function panels“.
rspio3b.lib	<GTSL directory>\Bin	Import Library
rspio3b.h	<GTSL directory>\Include	Header file for the driver



To use the driver, the IVI and VISA libraries from National Instruments are necessary.

### 7.2 Soft panel

A soft panel is available for the R&S TS-PIO3B Digital I/O module.

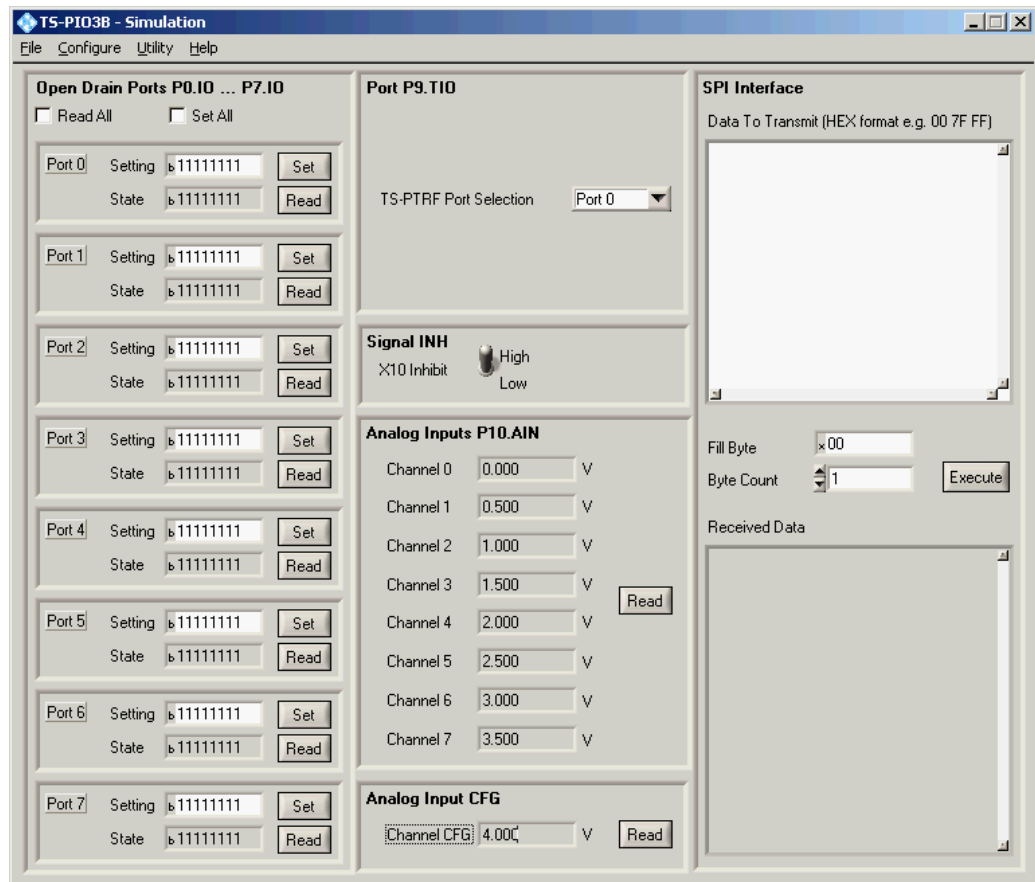

Figure 7-1: R&S TS-PIO3B soft panel



The operation of the soft panel is described in the "Software Description of the R&S GTSL".

## 7.3 Sample programs

### 7.3.1 Programming with DIOMGR

/\*

Error handling is not considered in this sample in order to keep it easy to read. The return status should be checked for "errorOccured" after each library call.

The following configuration files are used in this example:

```

physical.ini
-----

[device->PIO3B_13]
Description = "TS-PIO3B, Digital IO Module, Slot 13"
Type       = PIO3B
ResourceDesc = CAN0::0::1::13
DriverDll  = rspio3b.dll
DriverPrefix = rspio3b
DriverOption = "Simulate=0,RangeCheck=1"
SFTDll    = sftmpio3b.dll
SFTPrefix = SFTMPIO3B

Pio3bApplication.ini
-----

[bench->digitalTest]
Trace          = 0
Simulation     = 0
DIODEvice1    = device->PIO3B_13
DIOChannelTable = io_channel->digitalTest

[io_channel->digitalTest]
; TS-PIO3B channels at open drain port 0
CH_0_0 = PIO3B_13!p0io0
CH_0_1 = PIO3B_13!p0io1
CH_0_2 = PIO3B_13!p0io2
CH_0_3 = PIO3B_13!p0io3
CH_0_4 = PIO3B_13!p0io4
CH_0_5 = PIO3B_13!p0io5
CH_0_6 = PIO3B_13!p0io6
CH_0_7 = PIO3B_13!p0io7
; TS-PIO3B push/pull channels at port 9
CH_9_0 = PIO3B_13!p9tio0
CH_9_7 = PIO3B_13!p9tio7
; TS-PIO3B inhibit channel
Inh     = PIO3B_13!inh

*/
#include "resmgr.h"
#include "diomgr.h"

#define BUFF_SIZE 9

int main (int argc, char *argv[])
{
    long residDiomgr; /* resource ID for dio manager library */
    char resposeData[BUFF_SIZE];

    short errorOccurred = 0;

```

```

long  errorCode = 0;
char  errorMessage[GTSL_ERROR_BUFFER_SIZE] = "";

/* load the physical and application configuration files */
RESMGR_Setup (0, "physical.ini", "Pio3bApplication.ini",
              &errorOccurred, &errorCode, errorMessage);

/* initialize the dio manager library */
DIOMGR_Setup (0, "bench->digitalTest", &residDiomgr,
              &errorOccurred, &errorCode, errorMessage);

/* reset CH_0_0 */
DIOMGR_PortStimulus (0, residDiomgr, "CH_0_0=0",
                     &errorOccurred, &errorCode, errorMessage);

/* read state of CH_0_0 to CH_0_7 */
DIOMGR_PortResponse (0, residDiomgr,
                    "CH_0_7=X, CH_0_6=X, CH_0_5=X, CH_0_4=X,"
                    "CH_0_3=X, CH_0_2=X, CH_0_1=X, CH_0_0=X",
                    BUFF_SIZE, resposeData, VI_NULL, VI_NULL,
                    &errorOccurred, &errorCode, errorMessage);

/* reset CH_0_3 */
DIOMGR_PortStimulus (0, residDiomgr, "CH_0_3=0",
                     &errorOccurred, &errorCode, errorMessage);

/* read state of CH_0_0 to CH_0_7 */
DIOMGR_PortResponse (0, residDiomgr,
                    "CH_0_7=X, CH_0_6=X, CH_0_5=X, CH_0_4=X,"
                    "CH_0_3=X, CH_0_2=X, CH_0_1=X, CH_0_0=X",
                    BUFF_SIZE, resposeData, VI_NULL, VI_NULL,
                    &errorOccurred, &errorCode, errorMessage);

/* set CH_0_0 and CH_0_3 */
DIOMGR_PortStimulus ( 0, residDiomgr, "CH_0_0=1, CH_0_3=1",
                     &errorOccurred, &errorCode, errorMessage);

/* read state of CH_0_0 to CH_0_7 */
DIOMGR_PortResponse (0, residDiomgr,
                    "CH_0_7=X, CH_0_6=X, CH_0_5=X, CH_0_4=X,"
                    "CH_0_3=X, CH_0_2=X, CH_0_1=X, CH_0_0=X",
                    BUFF_SIZE, resposeData, VI_NULL, VI_NULL,
                    &errorOccurred, &errorCode, errorMessage);

/* reset inhibit channel INH */
DIOMGR_PortStimulus (0, residDiomgr, "INH=0",
                     &errorOccurred, &errorCode, errorMessage);

```



```

/* set inhibit channel INH */
DIOMGR_PortStimulus (0, residDiomgr, "INH=1",
                    &errorOccurred, &errorCode, errorMessage);

/* close the dio manager library */
DIOMGR_Cleanup (0, residDiomgr,
               &errorOccurred, &errorCode, errorMessage);

/* close resource manager library */
RESMGR_Cleanup (0, &errorOccurred, &errorCode, errorMessage);

return 0;
}

```

### 7.3.2 Programming with signal routing library

```
/* Programming example with signal routing library
```

The following configuration files are used in this example:

physical.ini

-----

```

[device->PIO3B_13]
Description = "TS-PIO3B, Digital IO Module, Slot 13"
Type       = PIO3B
ResourceDesc = CAN0::0::1::13
DriverDll   = rspio3b.dll
DriverPrefix = rspio3b
DriverOption = "Simulate=0,RangeCheck=1"
SFTDll      = sftmpio3b.dll
SFTPrefix   = SFTMPIO3B

; Analog bus pseudo-device, used by ROUTE
[device->ABUS]
Type       = AB

```

pio3bRouteApp.ini

-----

```

[ResourceManager]
; general trace settings (normally off)
Trace           = 0
TraceFile       = ResmgrTrace.txt

[LogicalNames]
RoutePio3b     = bench->rspio3bRoute

```

```

[bench->rspio3bRoute]
Description          = test bench
Simulation           = 0
Trace                = 0
SignalRoutingDisplay = 0
SwitchDevice1       = device->PIO3B
AnalogBus            = device->ABUS
AppChannelTable     = io_channel->test
SwitchSettings      = switch->test

[io_channel->test]
PXMI_G0_NO  = PIO3B!P1IO0
PXMI_G0_COM = PIO3B!GND

[switch->test]
; Connect supply via PXMI relay AZ832 (operating and debounce delay: 6 ms)
#CONNECT_PS = PXMI_G0_NO > PXMI_G0_COM, ?6
#DISCONNECT_PS = PXMI_G0_NO | PXMI_G0_COM, ?6
*/
#include <ansi_c.h>
#include "resmgr.h"
#include "route.h"

static short errorOccurred;
static long  errorCode;
static char  errorMessage[GTSL_ERROR_BUFFER_SIZE];
static long  residRoute;

static char  benchName[] = "bench->rspio3bRoute";

/* prototypes */
static void cs ( char * funcName );
static void runTest ( void );

/* FUNCTION *****/
/* loads the libraries and runs the test
*****/
int main (int argc, char *argv[])
{
    printf("Example using ROUTE functions for switching external relays\n\n");

    /* setup libraries */
    RESMGR_Setup (0, "physical.ini", "pio3bRouteApp.ini",
        &errorOccurred, &errorCode, errorMessage);
    cs("RESMGR_Setup");
}

```

```

if ( ! errorOccurred )
{
ROUTE_Setup (0, benchName, &residRoute,
&errorOccurred, &errorCode, errorMessage);
cs("ROUTE_Setup");
}

if ( ! errorOccurred )
{
runTest ( );
}

/* cleanup libraries */
ROUTE_Cleanup (0, residRoute, &errorOccurred, &errorCode, errorMessage);
cs("ROUTE_Cleanup");

RESMGR_Cleanup ( 0, &errorOccurred, &errorCode, errorMessage);
cs("RESMGR_Cleanup");

printf("\nPress 'Enter' to terminate\n");
getchar();

return 0;
}

/* FUNCTION *****/
/* checks the return status of a library call
*****/
static void cs ( char * funcName )
{
if ( errorOccurred )
{
printf ("%s returned 0x%08X\n%s\n\n", funcName, errorCode, errorMessage);
}
}

/* FUNCTION *****/
/* Executes some switch commands
*****/
static void runTest ( void )
{
/* connect power supply; wait time is specified in switch command */
if ( ! errorOccurred )
{
ROUTE_Execute (0, residRoute, "#CONNECT_PS",
&errorOccurred, &errorCode, errorMessage);
cs("ROUTE_Execute");
}
}

```

```

/* disconnect power supply; wait time is specified in switch command */
if ( ! errorOccurred )
{
    ROUTE_Execute (0, residRoute, "#DISCONNECT_PS",
        &errorOccurred, &errorCode, errorMessage);
    cs("ROUTE_Execute");
}
}

```

### 7.3.3 Programming with device drivers

```

/*
    Error handling is not considered in this sample in order to
    keep it easy to read. The return status should be checked for
    VI_SUCCESS after each driver call.
*/

#include "rspio3b.h"

#define  BUFF_SIZE    16

static ViChar txBuff[BUFF_SIZE];
static ViChar rxBuff[BUFF_SIZE];

int main (int argc, char *argv[])
{
    ViSession vi;
    ViStatus  status;
    ViUInt8   portVal;

    /*
        open a session to the device driver. The resource descriptor
        depends on the slot number of the module and must be adapted
        to the target system.
    */
    status = rspio3b_InitWithOptions ("CAN0::0::2::4::INSTR",
        VI_TRUE,
        VI_TRUE,
        "Simulate=0,RangeCheck=1",
        & vi);

    /* set port 0 bit 0 to active low */
    status = rspio3b_SetPort (vi, RSPIO3B_DIG_PORT_0, 0x01, 0x00);

    /* read port 0 */
    status = rspio3b_ReadPort (vi, RSPIO3B_DIG_PORT_0, & portVal);

    /* set port 0 bit 3 to active low */
    status = rspio3b_SetPort (vi, RSPIO3B_DIG_PORT_0, 0x04, 0x00);
}

```

```
/* read port 0 */
status = rspio3b_ReadPort (vi, RSPIO3B_DIG_PORT_0, & portVal);

/* set all bits of port 0 to active high */
status = rspio3b_SetPort (vi, RSPIO3B_DIG_PORT_0, 0xFF, 0xFF);

/* read port 0 */
status = rspio3b_ReadPort (vi, RSPIO3B_DIG_PORT_0, & portVal);

/* set signal INH to low */
status = rspio3b_SetInhibit (vi, VI_FALSE);

/* set signal INH to high again */
status = rspio3b_SetInhibit (vi, VI_TRUE);

/* SPI transfer to R&S TS-PTRF port 3; select port */
status = rspio3b_PtrfSelectPort (vi, RSPIO3B_VAL_PTRF_PORT_3);

/* start SPI transfer; store received data in s_rxBuffer */
txBuff[0] = 0x03;
txBuff[1] = 0x00;
txBuff[2] = 0x00;

status = rspio3b_SpiTransfer (vi, txBuff, rxBuff, BUFF_SIZE);

/* reset module, close the driver session */
status = rspio3b_close (vi);

return 0;
}
```

## 8 Maintenance, storage and disposal

### 8.1 Changing fuses

The optional modules R&S TS-PIO3B and R&S TS-PTR hold several SMD slow-blowing fuses with a nominal value of 2 A.

If the module does not work, it is possible that a blown fuse is the cause. The fuses are located on the side of the module.

1. Turn off the R&S TSVP base unit as described in the user manual of the base unit.
2. Remove the R&S TSVP from the power supply as described in the user manual of the base unit.
3. Remove the module as described in [Chapter 5, "Installation"](#), on page 33.
4. Check the condition of the fuse.
5. Replace the blown fuse. Only use a fuse of the specified type.  
The fuse type and its characteristics are indicated next to the fuse holder.
6. Reinsert the module.

### 8.2 Storage

Protect the product against dust. Ensure that the environmental conditions, e.g. temperature range and climatic load, meet the values specified in the data sheet.

### 8.3 Disposal

Rohde & Schwarz is committed to making careful, ecologically sound use of natural resources and minimizing the environmental footprint of our products. Help us by disposing of waste in a way that causes minimum environmental impact.

#### Disposing electrical and electronic equipment

A product that is labeled as follows cannot be disposed of in normal household waste after it has come to the end of its service life. Even disposal via the municipal collection points for waste electrical and electronic equipment is not permitted.



*Figure 8-1: Labeling in line with EU directive WEEE*

Rohde & Schwarz has developed a disposal concept for the eco-friendly disposal or recycling of waste material. As a manufacturer, Rohde & Schwarz completely fulfills its obligation to take back and dispose of electrical and electronic waste. Contact your local service representative to dispose of the product.

## 9 Troubleshooting

If the system is not running properly, try to find the problem with the following tests. If the tests do not help to locate the problem, contact your Rohde & Schwarz service representative.

**Table 9-1: Self-test capabilities of the modules**

	R&S TS-PIO3B	R&S TS-PTRF	R&S TS-PRIO4	R&S TS-PXM1	R&S TS-PTR
LED test	no	yes	no	yes	no
Automatic detection	yes	yes <sup>(1)</sup>	yes <sup>(1)</sup>	yes	no
Fuse test	yes	no	no	no	no

<sup>(1)</sup>: only in combination with R&S TS-PIO3B

### 9.1 LED test

The module has three LEDs on its front panel that indicate its status.

After turning on the system, all LEDs light up for a short time to indicate that the power supply is present and that all LEDs are working.

For more information about the meaning of the LED colors for each module, see the corresponding sections about the status LEDs in [Chapter 4, "Module tour"](#), on page 16.

### 9.2 R&S TSVP self-test

You can find information about starting the self-test and the order of required work steps as well as a detailed description of parameters and sequences that are tested in the R&S TSVP service manual.

#### 9.2.1 Automatic detection

Within the scope of the TSVP self-test and upon the start of the TSVP panel, the modules are identified. The above table lists the modules that can be detected automatically when connected to an R&S TS-PIO3B.

#### 9.2.2 Fuse test

During this test the fuses in the voltage supply lines +12 V, +5 V, +3.3 V (AUX1) and -12 V (AUX2) are checked. All voltages are applied via a negatively biased summing amplifier to the common input of the A/D converter.



If, for example, the AUX1 und AUX2 lines are activated via the jumpers X2 and X3 (default setting) and no voltages are applied on both AUX lines, a A/D converter voltage of 1.0 V is expected. This value must be within the limits of 0.875 and 1.125 V. A fuse defect changes this value by at least 250 mV and can therefore be detected.

Changing the default jumper settings X2 and X3 or applying an external voltage on the AUX lines by the user, changes the expected A/D converter voltage. In this case the limits against which the value shall be compared, can be manually specified by the user in the file `physical.ini` within the relevant section for the module R&S TS-PIO3B. Example:

```
SFTFuseTest = 1.2,0.8
```

```
(SFTFuseTest = <upper limit/V>,<lower limit/V>)
```

See also [Chapter 4.1.5, "Voltage sources"](#), on page 20.

## 9.3 Contacting customer support

### Technical support – where and when you need it

For quick, expert help with any Rohde & Schwarz product, contact our customer support center. A team of highly qualified engineers provides support and works with you to find a solution to your query on any aspect of the operation, programming or applications of Rohde & Schwarz products.

### Contact information

Contact our customer support center at [www.rohde-schwarz.com/support](http://www.rohde-schwarz.com/support), or follow this QR code:



Figure 9-1: QR code to the Rohde & Schwarz support page

# Annex

## A Specifications

For an overview of technical specifications of the R&S TS-PIO3B module, refer to the corresponding product brochure / data sheet.

If discrepancies exist between information in this manual and the values in the data sheet, the values in the data sheet take precedence.

## B Block diagrams

This chapter contains block diagrams and mechanical layout drawings of the modules.

### B.1 R&S TS-PIO3B

The R&S TS-PIO3B module is designed as a short plug-in card for installation on the front of the R&S TSVP frames. The X10 connector on the front either serves for the direct connection of devices under test or for connecting the R&S TS-PTRF adapter module. The X20/X1 connectors connect the module with the control backplane.

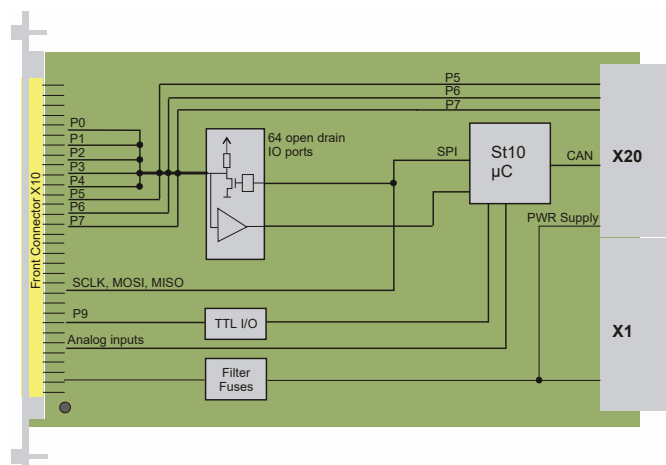

**Figure B-1: Simplified diagram and mechanical structure of the R&S TS-PIO3B (1512.4407.02)**

For variant 04 (1512.4407.04), ports P5, P6 and P7 are not connected to function block "open drain I/O ports". The ports are passive connections between X20 and X10 (analog to TS-PTR).

## B.2 R&S TS-PRIO4

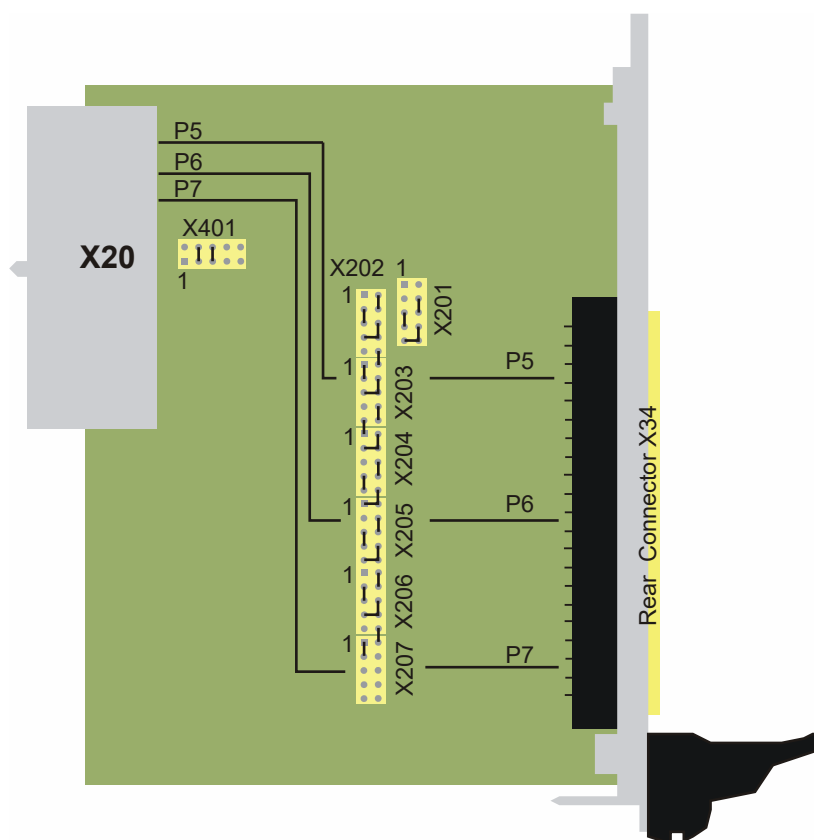

Figure B-2: Simplified diagram and mechanical structure of the R&S TS-PRIO4 module

## B.3 R&S TS-PTR

The R&S TS-PTR module is designed as a short plug-in card (approx. 160 x 100 mm) for installation on the front of the R&S TSVP frames. The X10 connector on the front either serves for the direct connection of devices under test or for connecting the R&S TS-PTRF adapter module. X20 connects the module to the control backplane of the R&S TSVP frame.

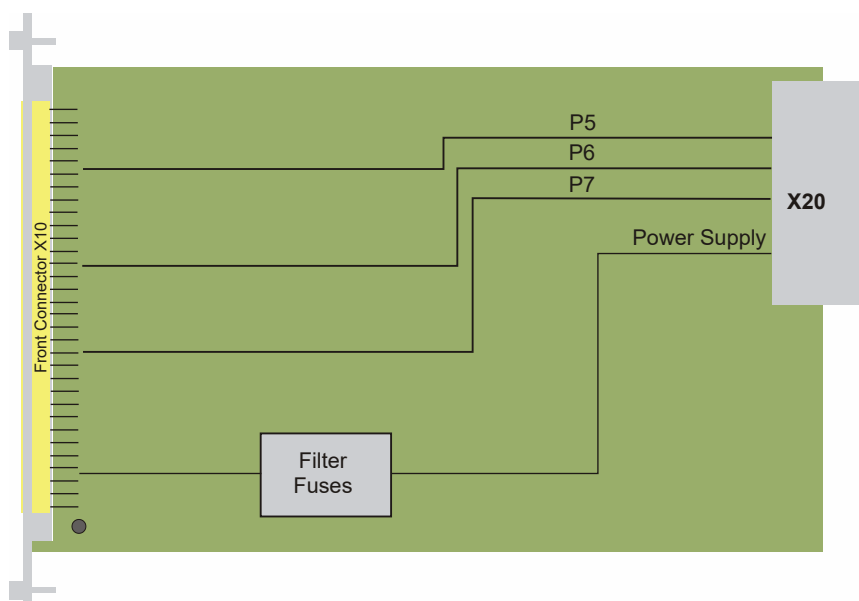

Figure B-3: Simplified diagram and mechanical structure of the R&S TS-PTR

### B.4 R&S TS-PTRF

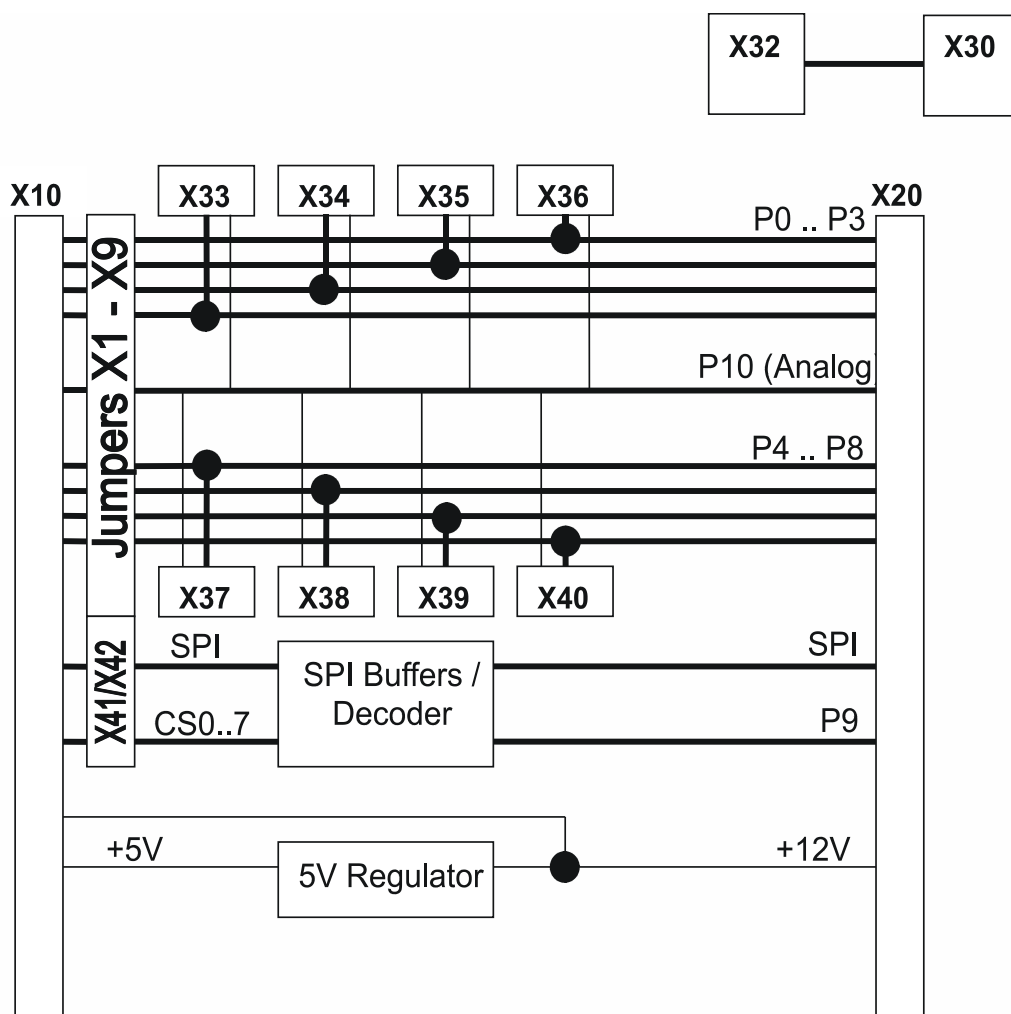

Figure B-4: Block diagram of the R&S TS-PTRF

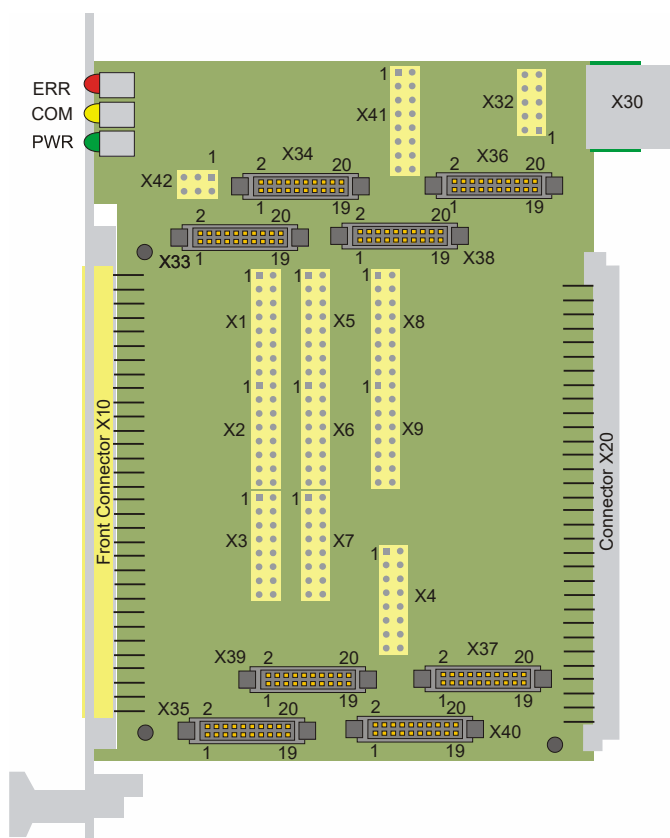

Figure B-5: Mechanical Layout of the R&S TS-PTRF

### B.5 R&S TS-PXM1

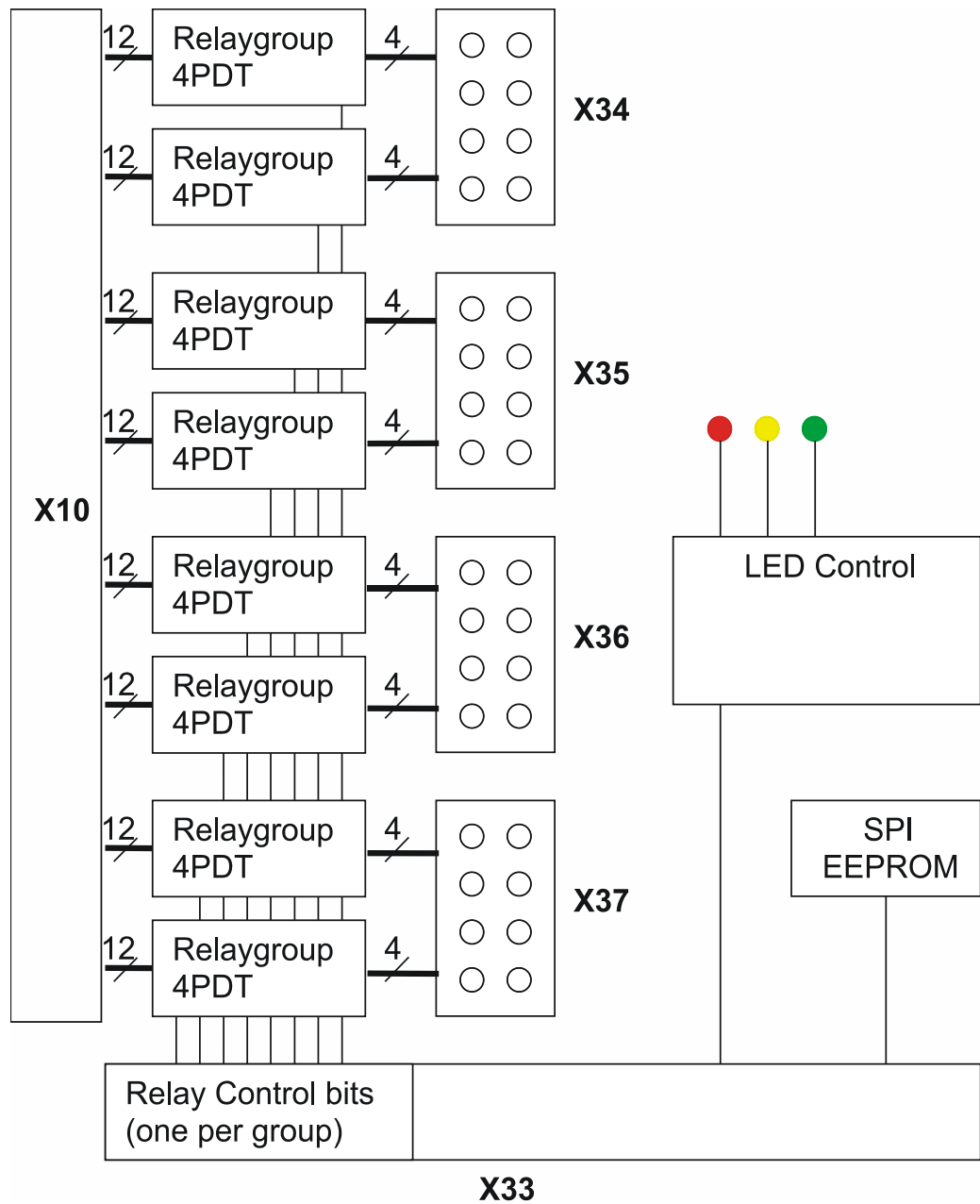

Figure B-6: Function block diagram of the R&S TS-PXM1



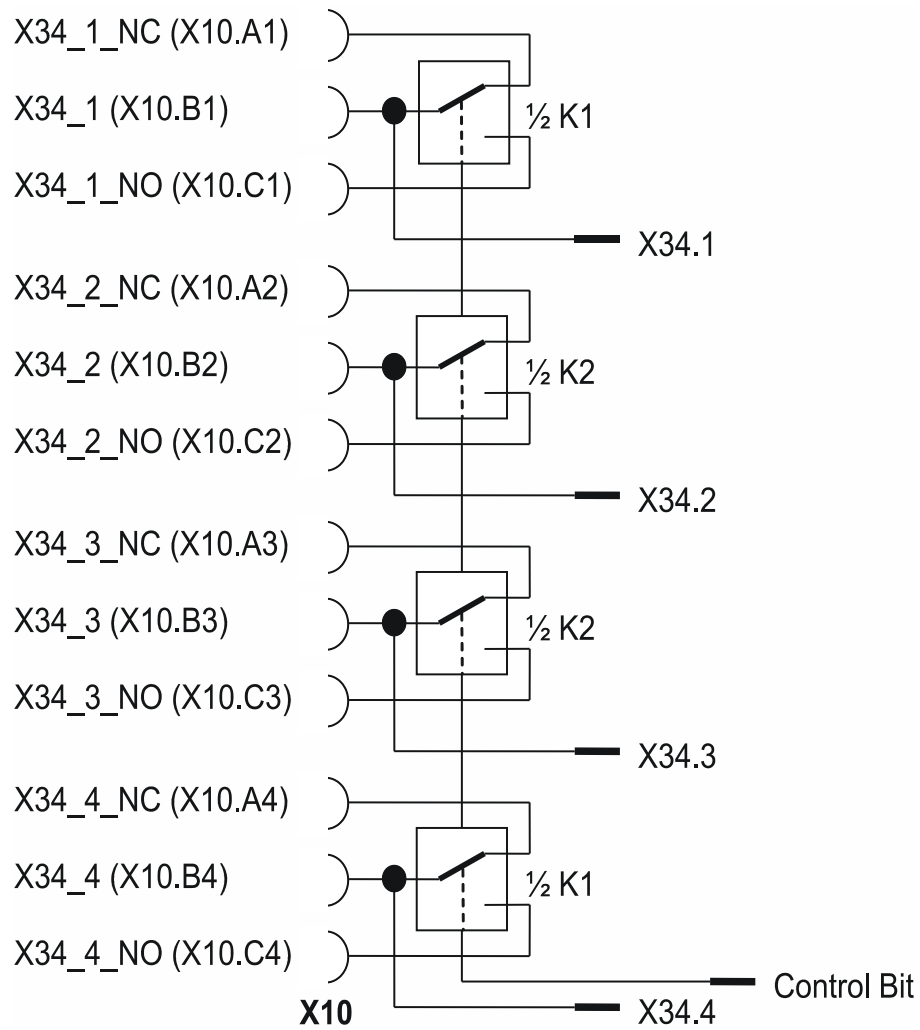

Figure B-7: R&S TS-PXM1 detailed example : Relay module X34.1- X34.4

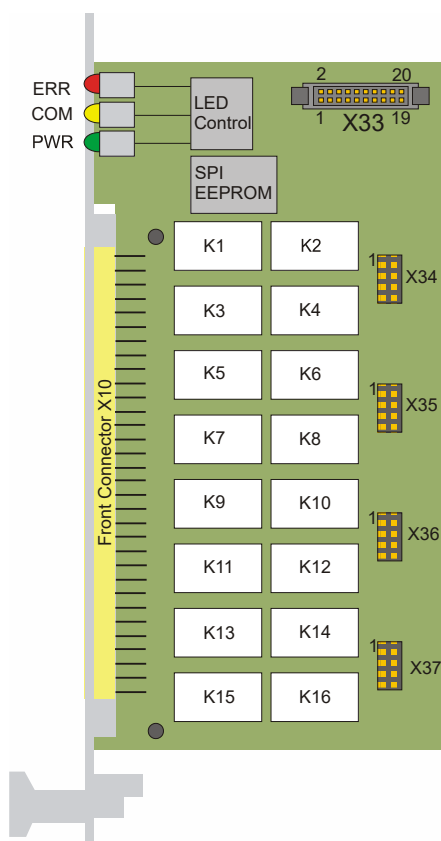

Figure B-8: Mechanical Layout of the R&S TS-PXM1

## C Interface description

This chapter contains a description of the module interfaces.

### C.1 R&S TS-PIO3B

#### C.1.1 X10 connector on the front

X10 connector type: 96-pin VG connector



Figure C-1: R&S TS-PIO3B X10 connector (view: plug-in side)

Table C-1: R&S TS-PIO3B, assignment of the x10 connector

X10	a	b	c
1	P0.IO0	P5.IO0	P3.IO0
2	P0.IO1	P5.IO1	P3.IO1
3	P0.IO2	P5.IO2	P3.IO2
4	P0.IO3	P5.IO3	P3.IO3
5	P0.IO4	P5.IO4	P3.IO4
6	P0.IO5	P5.IO5	P3.IO5

X10	a	b	c
7	P0.IO6	P5.IO6	P3.IO6
8	P0.IO7	P5.IO7	P3.IO7
9	P1.IO0	P6.IO0	P4.IO0
10	P1.IO1	P6.IO1	P4.IO1
11	P1.IO2	P6.IO2	P4.IO2
12	P1.IO3	P6.IO3	P4.IO3
13	P1.IO4	P6.IO4	P4.IO4
14	P1.IO5	P6.IO5	P4.IO5
15	P1.IO6	P6.IO6	P4.IO6
16	P1.IO7	P6.IO7	P4.IO7
17	P2.IO0	P7.IO0	P9.TIO0
18	P2.IO1	P7.IO1	P9.TIO1
19	P2.IO2	P7.IO2	P9.TIO2
20	P2.IO3	P7.IO3	P9.TIO3
21	P2.IO4	P7.IO4	P9.TIO4
22	P2.IO5	P7.IO5	P9.TIO5
23	P2.IO6	P7.IO6	P9.TIO6
24	P2.IO7	P7.IO7	P9.TIO7
25	P10.AIN0	SCLK	CFG_AIN (*)
26	P10.AIN1	MISO	INH
27	P10.AIN2	MOSI	AUX1 (*)
28	P10.AIN3	AUX1 (*)	AUX2 (*)
29	P10.AIN4	AUX2 (*)	+5V
30	P10.AIN5	+5V	+12V
31	P10.AIN6	+12V	GND
32	P10.AIN7	GND	CHA_GND

(\*) : To prevent malfunctions, do not use the signals.

## C.1.2 Connector X1

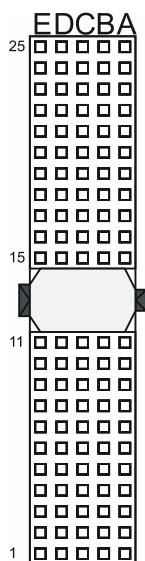

Figure C-2: R&S TS-PIO3B X1 connector

Table C-2: R&S TS-PIO3B, assignment of the x1 connector

Pin	Z	A	B	C	D	E	F
25	GND	+5V_IN				+5V_IN	GND
24	GND		+5V_IN				GND
23	GND	+3,3V_IN					GND
22	GND		GND	+3,3V_IN			GND
21	GND	+3,3V_IN					GND
20	GND		GND				GND
19	GND	+3,3V_IN			GND		GND
18	GND		GND	+3,3V_IN			GND
17	GND	+3,3V_IN			GND		GND
16	GND		GND				GND
15	GND	+3,3V_IN					GND
14	Coding						Coding
13							
12							
11	GND				GND		GND
10	GND		GND	+3,3V_IN			GND
9	GND				GND		GND
8	GND		GND				GND

Pin	Z	A	B	C	D	E	F
7	GND				GND		GND
6	GND		GND	+3,3V_IN			GND
5	GND				GND		GND
4	GND						GND
3	GND				+5V_IN		GND
2	GND						GND
1	GND	+5V_IN	-12V_IN		+12V_IN	+5V_IN	GND

### C.1.3 Connector X20

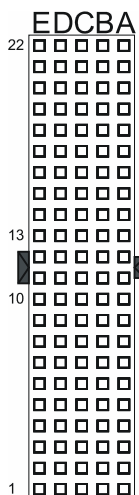

Figure C-3: R&S TS-PIO3B X20 connector

Table C-3: R&S TS-PIO3B, assignment of the x20 connector

Pin	Z	A	B	C	D	E	F
22		GA4	GA3	GA2	GA1	GA0	
21			GA5				
20		AUX2	AUX1	+5V	GND	+5V	
19		-12V	GND	+5V	AUX2	AUX1	
18		PXI_TRIG 3	PXI_TRIG 4	PXI_TRIG 5	CANEN	PXI_TRIG 6	
17		PXI_TRIG 2	GND	RRS232_RX	RRS232_TX	PXI_CLK1 0	
16		PXI_TRIG 1	PXI_TRIG 0	RRS232_RT S	GND	PXI_TRIG 7	
15			GND	RRS232_CT S	+5V		

Pin	Z	A	B	C	D	E	F
14			RSLED[0] □ (RED)	RSLED[1] □ (YEL- LOW)	RSLED[2] □ (GREEN)		
13							
12	Coding	P7.IO0		P6.IO0		P5.IO0	Coding
11		P7.IO1		P6.IO1		P5.IO1	
10		P7.IO2		P6.IO2		P5.IO2	
9		P7.IO3		P6.IO3		P5.IO3	
8		P7.IO4		P6.IO4		P5.IO4	
7		P7.IO5		P6.IO5		P5.IO5	
6		P7.IO6		P6.IO6		P5.IO6	
5		P7.IO7		P6.IO7		P5.IO7	
4							
3		RSDO	GND		RINH	RSA0	
2		RSCLK	RSA2	RSA1	RSDI	+12V	
1		RCS	GND	CAN_H	CAN_L	+5V	

### C.1.4 X40 connector

X40 connector type: 3 mm connector, double-row, 14-pin

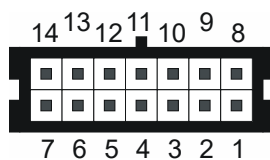

Figure C-4: R&S TS-PIO3B X40 connector

Table C-4: R&S TS-PIO3B, assignment of the x40 connector

Pin	Assignment	Pin	Assignment
1	GND	8	GND
1	GND	9	AUX 2
3	+5 V	10	GND
4	GND	11	CAN_H
5	+12 V	12	CAN_L
6	GND	13	GND
7	AUX 1	14	GND

### C.1.5 Jumper X2

See [Chapter 4.1.5, "Voltage sources"](#), on page 20.

### C.1.6 Jumper X3

See [Chapter 4.1.5, "Voltage sources"](#), on page 20.

## C.2 R&S TS-PRIO4

### C.2.1 Connector X20

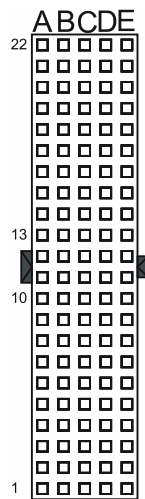

Figure C-5: R&S TS-PRIO4 X20 connector

Table C-5: R&S TS-PRIO4, assignment of the x20 connector

Pin	Z	A	B	C	D	E	F
22							
21							
20					GND		
19			GND				
18							
17			GND				
16					GND		
15			GND				
14							



Pin	Z	A	B	C	D	E	F
13							
12	Codierung	P7.IO0		P6.IO0		P5.IO0	Codierung
11		P7.IO1		P6.IO1		P5.IO1	
10		P7.IO2		P6.IO2		P5.IO2	
9		P7.IO3		P6.IO3		P5.IO3	
8		P7.IO4		P6.IO4		P5.IO4	
7		P7.IO5		P6.IO5		P5.IO5	
6		P7.IO6		P6.IO6		P5.IO6	
5		P7.IO7		P6.IO7		P5.IO7	
4							
3			GND				
2							
1			GND				

### C.2.2 Rear connector X34

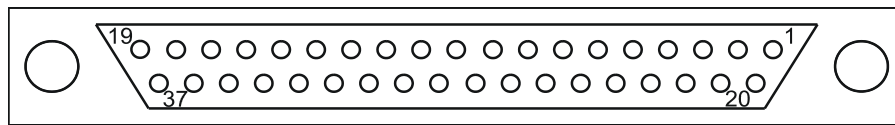

Figure C-6: R&S TS-PRIO4 X34 connector

Table C-6: R&S TS-PRIO4, assignment of the x34 connector

Pin	Signal	Pin	Signal
1	GND	20	
2		21	
3		22	P6.IO7
4		23	P5.IO0
5	P5.IO1	24	P6.IO0
6		25	P5.IO2
7	P5.IO3	26	P6.IO1
8		27	P5.IO4
9	P5.IO5	28	P6.IO2
10		29	P5.IO6
11	P5.IO7	30	P6.IO3

Pin	Signal	Pin	Signal
12		31	P7.IO0
13	P7.IO1	32	P6.IO4
14		33	P7.IO2
15	P7.IO3	34	P6.IO5
16		35	P7.IO4
17	P7.IO5	36	P6.IO6
18		37	P7.IO6
19	P7.IO7		

### C.2.3 Jumpers



The jumpers on the module have been correctly configured ex works. They must not be changed.

The delivery status is described in the following.

X401	3-4
	5-6
X201	4-6
	5-7
	8-10
	9-10
X202	2-4
	3-5
	6-8
	7-8
	10-X203.2
X203	1-3
	4-6
	5-6
	8-10
	9-X204.1
X204	2-4
	3-4

	6-8
	7-9
	10-X205.2
X205	1-2
	4-6
	5-7
	8-10
	9-10
X206	2-4
	3-5
	6-8
	7-8
	10-X207.2
X207	1-3

## C.3 R&S TS-PTR

### C.3.1 X10 connector on the front

X10 connector type: 96-pin VG connector



Figure C-7: R&S TS-PTR X10 connector (view: plug-in side)

Table C-7: R&S TS-PTR, assignment of the x10 connector

X10	a	b	c
1		P5.IO0	
2		P5.IO1	
3		P5.IO2	
4		P5.IO3	
5		P5.IO4	
6		P5.IO5	
7		P5.IO6	
8		P5.IO7	
9		P6.IO0	
10		P6.IO1	
11		P6.IO2	
12		P6.IO3	
13		P6.IO4	
14		P6.IO5	
15		P6.IO6	
16		P6.IO7	

X10	a	b	c
17		P7.IO0	
18		P7.IO1	
19		P7.IO2	
20		P7.IO3	
21		P7.IO4	
22		P7.IO5	
23		P7.IO6	
24		P7.IO7	
25			
26			
27			
28			
29			+5V
30		+5V	+12V
31		+12V	GND
32		GND	CHA_GND

### C.3.2 Connector X20

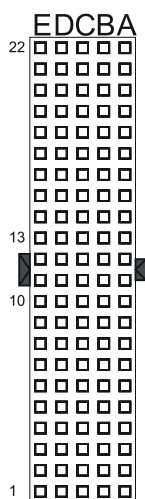

Figure C-8: R&S TS-PTR X20 connector

Table C-8: R&amp;S TS-PTR, assignment of the x20 connector

Pin	Z	A	B	C	D	E	F
22							
21							
20				+5V	GND	+5V	
19			GND	+5V			
18							
17			GND				
16					GND		
15			GND		+5V		
14							
13							
12	Codierung	P7.IO0		P6.IO0		P5.IO0	Codierung
11		P7.IO1		P6.IO1		P5.IO1	
10		P7.IO2		P6.IO2		P5.IO2	
9		P7.IO3		P6.IO3		P5.IO3	
8		P7.IO4		P6.IO4		P5.IO4	
7		P7.IO5		P6.IO5		P5.IO5	
6		P7.IO6		P6.IO6		P5.IO6	
5		P7.IO7		P6.IO7		P5.IO7	
4							
3			GND				
2						+12V	
1			GND			+5V	

## C.4 R&S TS-PTRF

### C.4.1 X10 connector on the front

X10 connector type: 96-pin VG connector



Figure C-9: R&S TS-PTRF X10 connector (view: plug-in side)

Table C-9: R&S TS-PTRF, assignment of the x10 connector

X10	a	b	c
1	EXT_P0.IO0	EXT_P5.IO0	EXT_P3.IO0
2	EXT_P0.IO1	EXT_P5.IO1	EXT_P3.IO1
3	EXT_P0.IO2	EXT_P5.IO2	EXT_P3.IO2
4	EXT_P0.IO3	EXT_P5.IO3	EXT_P3.IO3
5	EXT_P0.IO4	EXT_P5.IO4	EXT_P3.IO4
6	EXT_P0.IO5	EXT_P5.IO5	EXT_P3.IO5
7	EXT_P0.IO6	EXT_P5.IO6	EXT_P3.IO6
8	EXT_P0.IO7	EXT_P5.IO7	EXT_P3.IO7
9	EXT_P1.IO0	EXT_P6.IO0	EXT_P4.IO0
10	EXT_P1.IO1	EXT_P6.IO1	EXT_P4.IO1
11	EXT_P1.IO2	EXT_P6.IO2	EXT_P4.IO2
12	EXT_P1.IO3	EXT_P6.IO3	EXT_P4.IO3
13	EXT_P1.IO4	EXT_P6.IO4	EXT_P4.IO4
14	EXT_P1.IO5	EXT_P6.IO5	EXT_P4.IO5
15	EXT_P1.IO6	EXT_P6.IO6	EXT_P4.IO6
16	EXT_P1.IO7	EXT_P6.IO7	EXT_P4.IO7

X10	a	b	c
17	EXT_P2.IO0	EXT_P7.IO0	E_CS0
18	EXT_P2.IO1	EXT_P7.IO1	E_CS1
19	EXT_P2.IO2	EXT_P7.IO2	E_CS2
20	EXT_P2.IO3	EXT_P7.IO3	E_CS3
21	EXT_P2.IO4	EXT_P7.IO4	E_CS4
22	EXT_P2.IO5	EXT_P7.IO5	E_CS5
23	EXT_P2.IO6	EXT_P7.IO6	E_CS6
24	EXT_P2.IO7	EXT_P7.IO7	E_CS7
25	EXT_P10.AIN0	E_SCLK	
26	EXT_P10.AIN1	E_MISO	INH
27	EXT_P10.AIN2	E_MOSI	AUX1 (*)
28	EXT_P10.AIN3	AUX1 (*)	AUX2 (*)
29	EXT_P10.AIN4	AUX2 (*)	+5V
30	EXT_P10.AIN5	+5V	+12V
31	EXT_P10.AIN6	+12V	GND
32	EXT_P10.AIN7	GND	CHA_GND

(\*) : Signals must not be used to prevent malfunctions.

#### C.4.2 Internal X20 connector

X20 connector type: 96-pin VG connector, plug



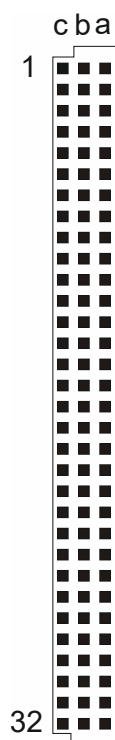

Figure C-10: R&S TS-PTRF X20 connector (view: plug-in side)

Table C-10: R&S TS-PTRF, assignment of the x20 connector

X10	a	b	c
1	P0.IO0	P5.IO0	P3.IO0
2	P0.IO1	P5.IO1	P3.IO1
3	P0.IO2	P5.IO2	P3.IO2
4	P0.IO3	P5.IO3	P3.IO3
5	P0.IO4	P5.IO4	P3.IO4
6	P0.IO5	P5.IO5	P3.IO5
7	P0.IO6	P5.IO6	P3.IO6
8	P0.IO7	P5.IO7	P3.IO7
9	P1.IO0	P6.IO0	P4.IO0
10	P1.IO1	P6.IO1	P4.IO1
11	P1.IO2	P6.IO2	P4.IO2
12	P1.IO3	P6.IO3	P4.IO3
13	P1.IO4	P6.IO4	P4.IO4
14	P1.IO5	P6.IO5	P4.IO5
15	P1.IO6	P6.IO6	P4.IO6
16	P1.IO7	P6.IO7	P4.IO7

X10	a	b	c
17	P2.IO0	P7.IO0	P9.TIO0
18	P2.IO1	P7.IO1	P9.TIO1
19	P2.IO2	P7.IO2	P9.TIO2
20	P2.IO3	P7.IO3	P9.TIO3
21	P2.IO4	P7.IO4	P9.TIO4
22	P2.IO5	P7.IO5	P9.TIO5
23	P2.IO6	P7.IO6	P9.TIO6
24	P2.IO7	P7.IO7	P9.TIO7
25	P10.AIN0	SCLK	CFG_AIN
26	P10.AIN1	MISO	INH
27	P10.AIN2	MOSI	AUX1
28	P10.AIN3	AUX1	AUX2
29	P10.AIN4	AUX2	+5V
30	P10.AIN5	+5V	+12V
31	P10.AIN6	+12V	GND
32	P10.AIN7	GND	CHA_GND

### C.4.3 Internal X33 connector

X33 connector type: 20-pin connector, double-row, 2 mm grid

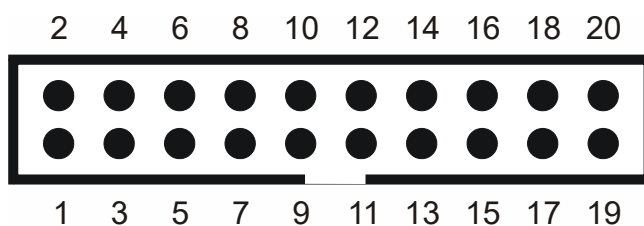

Figure C-11: R&S TS-PTRF X33 connector

Table C-11: R&S TS-PTRF, assignment of the x33 connector

X33			
1	GND	P0.IO0	2
3	P0.IO1	P0.IO2	4
5	P0.IO3	P0.IO4	6
7	P0.IO5	P0.IO6	8
9	P0.IO7	P10.AIN0	10
11	B_SCLK	B_MOSI	12

X33			
13	B_MISO	CS0	14
15	free	reserved	16
17	+5V	+5V	18
19	+12V	GND	20

#### C.4.4 Internal X34 connector

X34 connector type: 20-pin connector, double-row, 2 mm grid

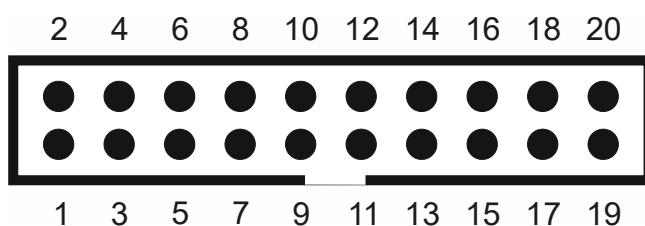

Figure C-12: R&S TS-PTRF X34 connector

Table C-12: R&S TS-PTRF, assignment of the x34 connector

X34			
1	GND	P1.IO0	2
3	P1.IO1	P1.IO2	4
5	P1.IO3	P1.IO4	6
7	P1.IO5	P1.IO6	8
9	P1.IO7	P10.AIN1	10
11	B_SCLK	B_MOSI	12
13	B_MISO	CS0	14
15	free	reserved	16
17	+5V	+5V	18
19	+12V	GND	20

#### C.4.5 Internal X35 connector

X35 connector type: 20-pin connector, double-row, 2 mm grid

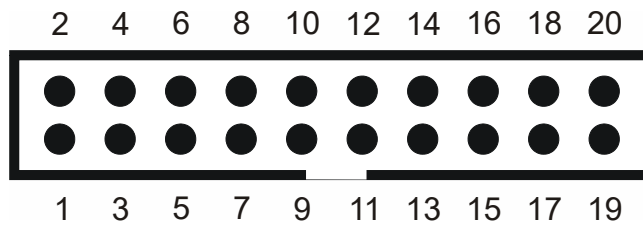

Figure C-13: R&amp;S TS-PTRF X35 connector

Table C-13: R&amp;S TS-PTRF, assignment of the x35 connector

X35			
1	GND	P2.IO0	2
3	P2.IO1	P2.IO2	4
5	P2.IO3	P2.IO4	6
7	P2.IO5	P2.IO6	8
9	P2.IO7	P10.AIN2	10
11	B_SCLK	B_MOSI	12
13	B_MISO	CS0	14
15	free	reserved	16
17	+5V	+5V	18
19	+12V	GND	20

#### C.4.6 Internal X36 connector

X36 connector type: 20-pin connector, double-row, 2 mm grid

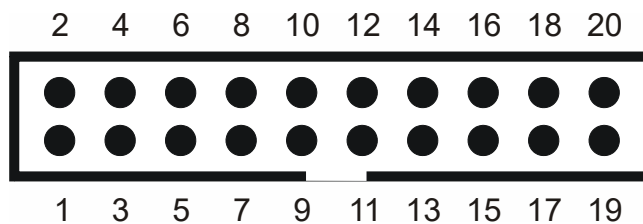

Figure C-14: R&amp;S TS-PTRF X36 connector

Table C-14: R&amp;S TS-PTRF, assignment of the x36 connector

X36			
1	GND	P3.IO0	2
3	P3.IO1	P3.IO2	4
5	P3.IO3	P3.IO4	6
7	P3.IO5	P3.IO6	8
9	P3.IO7	P10.AIN3	10

X36			
11	B_SCLK	B_MOSI	12
13	B_MISO	CS0	14
15	free	reserved	16
17	+5V	+5V	18
19	+12V	GND	20

#### C.4.7 Internal X37 connector

X37 connector type: 20-pin connector, double-row, 2 mm grid

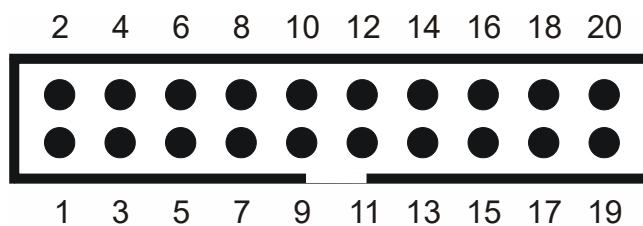

Figure C-15: R&S TS-PTRF X37 connector

Table C-15: R&S TS-PTRF, assignment of the x37 connector

X37			
1	GND	P4.IO0	2
3	P4.IO1	P4.IO2	4
5	P4.IO3	P4.IO4	6
7	P4.IO5	P4.IO6	8
9	P4.IO7	P10.AIN4	10
11	B_SCLK	B_MOSI	12
13	B_MISO	CS0	14
15	free	reserved	16
17	+5V	+5V	18
19	+12V	GND	20

#### C.4.8 Internal X38 connector

X38 connector type: 20-pin connector, double-row, 2 mm grid

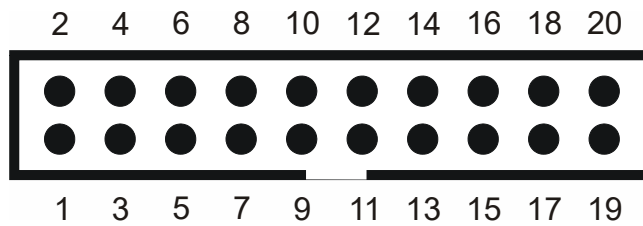

Figure C-16: R&amp;S TS-PTRF X38 connector

Table C-16: R&amp;S TS-PTRF, assignment of the x38 connector

X38			
1	GND	P5.IO0	2
3	P5.IO1	P5.IO2	4
5	P5.IO3	P5.IO4	6
7	P5.IO5	P5.IO6	8
9	P5.IO7	P10.AIN5	10
11	B_SCLK	B_MOSI	12
13	B_MISO	CS0	14
15	free	reserved	16
17	+5V	+5V	18
19	+12V	GND	20

#### C.4.9 Internal X39 connector

X39 connector type: 20-pin connector, double-row, 2 mm grid

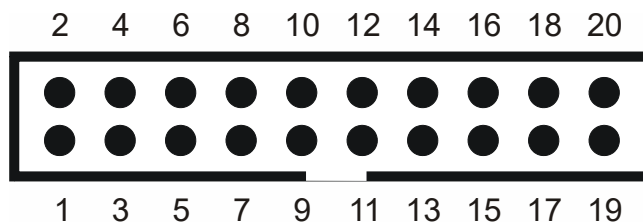

Figure C-17: R&amp;S TS-PTRF X39 connector

Table C-17: R&amp;S TS-PTRF, assignment of the x39 connector

X39			
1	GND	P6.IO0	2
3	P6.IO1	P6.IO2	4
5	P6.IO3	P6.IO4	6
7	P6.IO5	P6.IO6	8
9	P6.IO7	P10.AIN6	10

X39			
11	B_SCLK	B_MOSI	12
13	B_MISO	CS0	14
15	free	reserved	16
17	+5V	+5V	18
19	+12V	GND	20

#### C.4.10 Internal X40 connector

X40 connector type: 20-pin connector, double-row, 2 mm grid

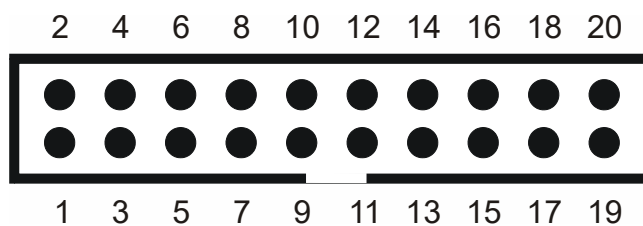

Figure C-18: R&S TS-PTRF X40 connector

Table C-18: R&S TS-PTRF, assignment of the x40 connector

X40			
1	GND	P7.IO0	2
3	P7.IO1	P7.IO2	4
5	P7.IO3	P7.IO4	6
7	P7.IO5	P7.IO6	8
9	P7.IO7	P10.AIN7	10
11	B_SCLK	B_MOSI	12
13	B_MISO	CS0	14
15	free	reserved	16
17	+5V	+5V	18
19	+12V	GND	20

#### C.4.11 Internal X1 connector

X1 connector type: 16-pin connector, double-row, 2.54 mm grid

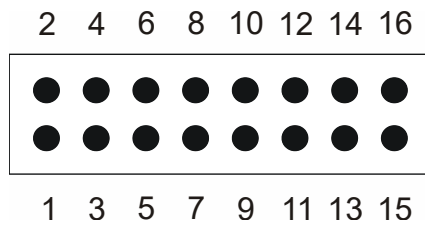

Figure C-19: R&S TS-PTRF X1 connector

Table C-19: R&S TS-PTRF, assignment of the x1 connector

X1			
1	EXT_P0.IO0	P0.IO0	2
3	EXT_P0.IO1	P0.IO1	4
5	EXT_P0.IO2	P0.IO2	6
7	EXT_P0.IO3	P0.IO3	8
9	EXT_P0.IO4	P0.IO4	10
11	EXT_P0.IO5	P0.IO5	12
13	EXT_P0.IO6	P0.IO6	14
15	EXT_P0.IO7	P0.IO7	16

#### C.4.12 Internal X2 connector

X2 connector type: 16-pin connector, double-row, 2.54 mm grid

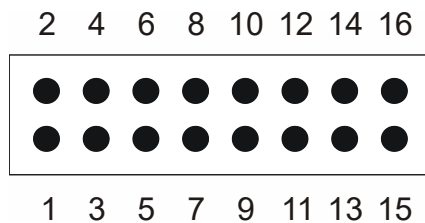

Figure C-20: R&S TS-PTRF X2 connector

Table C-20: R&S TS-PTRF, assignment of the x2 connector

X2			
1	EXT_P1.IO0	P1.IO0	2
3	EXT_P1.IO1	P1.IO1	4
5	EXT_P1.IO2	P1.IO2	6
7	EXT_P1.IO3	P1.IO3	8
9	EXT_P1.IO4	P1.IO4	10
11	EXT_P1.IO5	P1.IO5	12



X2			
13	EXT_P1.IO6	P1.IO6	14
15	EXT_P1.IO7	P1.IO7	16

### C.4.13 Internal X3 connector

X3 connector type: 16-pin connector, double-row, 2.54 mm grid

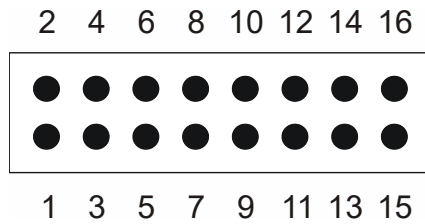

Figure C-21: R&S TS-PTRF X3 connector

Table C-21: R&S TS-PTRF, assignment of the x3 connector

X3			
1	EXT_P2.IO0	P2.IO0	2
3	EXT_P2.IO1	P2.IO1	4
5	EXT_P2.IO2	P2.IO2	6
7	EXT_P2.IO3	P2.IO3	8
9	EXT_P2.IO4	P2.IO4	10
11	EXT_P2.IO5	P2.IO5	12
13	EXT_P2.IO6	P2.IO6	14
15	EXT_P2.IO7	P2.IO7	16

### C.4.14 Internal X4 connector

X4 connector type: 16-pin connector, double-row, 2.54 mm grid

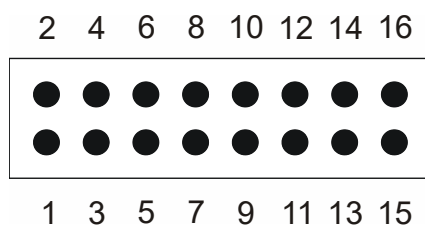

Figure C-22: R&S TS-PTRF X4 connector

Table C-22: R&amp;S TS-PTRF, assignment of the x4 connector

X4			
1	EXT_P10. AIN 0	P10. AIN 0	2
3	EXT_P10. AIN 1	P10. AIN 1	4
5	EXT_P10. AIN 2	P10. AIN 2	6
7	EXT_P10. AIN 3	P10. AIN 3	8
9	EXT_P10. AIN 4	P10. AIN 4	10
11	EXT_P10. AIN 5	P10. AIN 5	12
13	EXT_P10. AIN 6	P10. AIN 6	14
15	EXT_P10. AIN 7	P10. AIN 7	16

### C.4.15 Internal X5 connector

X5 connector type: 16-pin connector, double-row, 2.54 mm grid

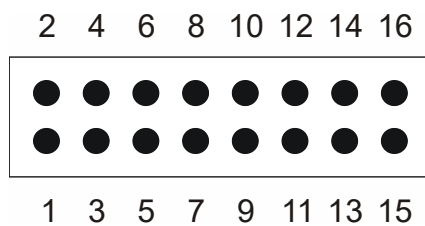

Figure C-23: R&amp;S TS-PTRF X5 connector

Table C-23: R&amp;S TS-PTRF, assignment of the x5 connector

X5			
1	EXT_P5.IO0	P5.IO0	2
3	EXT_P5.IO1	P5.IO1	4
5	EXT_P5.IO2	P5.IO2	6
7	EXT_P5.IO3	P5.IO3	8
9	EXT_P5.IO4	P5.IO4	10
11	EXT_P5.IO5	P5.IO5	12
13	EXT_P5.IO6	P5.IO6	14
15	EXT_P5.IO7	P5.IO7	16

### C.4.16 Internal X6 connector

X6 connector type: 16-pin connector, double-row, 2.54 mm grid

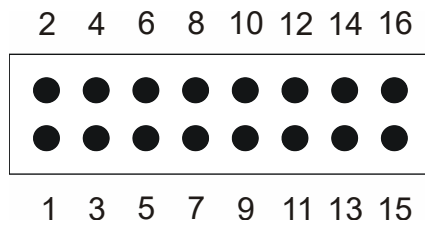

Figure C-24: R&amp;S TS-PTRF X6 connector

Table C-24: R&amp;S TS-PTRF, assignment of the x6 connector

X6			
1	EXT_P6.IO0	P6.IO0	2
3	EXT_P6.IO1	P6.IO1	4
5	EXT_P6.IO2	P6.IO2	6
7	EXT_P6.IO3	P6.IO3	8
9	EXT_P6.IO4	P6.IO4	10
11	EXT_P6.IO5	P6.IO5	12
13	EXT_P6.IO6	P6.IO6	14
15	EXT_P6.IO7	P6.IO7	16

### C.4.17 Internal X7 connector

X7 connector type: 16-pin connector, double-row, 2.54 mm grid

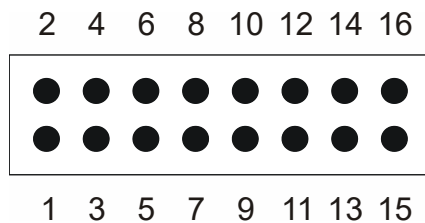

Figure C-25: R&amp;S TS-PTRF X7 connector

Table C-25: R&amp;S TS-PTRF, assignment of the x7 connector

X7			
1	EXT_P7.IO0	P7.IO0	2
3	EXT_P7.IO1	P7.IO1	4
5	EXT_P7.IO2	P7.IO2	6
7	EXT_P7.IO3	P7.IO3	8
9	EXT_P7.IO4	P7.IO4	10
11	EXT_P7.IO5	P7.IO5	12

X7			
13	EXT_P7.IO6	P7.IO6	14
15	EXT_P7.IO7	P7.IO7	16

#### C.4.18 Internal X8 connector

X8 connector type: 16-pin connector, double-row, 2.54 mm grid

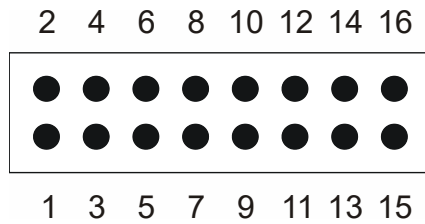

Figure C-26: R&S TS-PTRF X8 connector

Table C-26: R&S TS-PTRF, assignment of the x8 connector

X8			
1	EXT_P3.IO0	P3.IO0	2
3	EXT_P3.IO1	P3.IO1	4
5	EXT_P3.IO2	P3.IO2	6
7	EXT_P3.IO3	P3.IO3	8
9	EXT_P3.IO4	P3.IO4	10
11	EXT_P3.IO5	P3.IO5	12
13	EXT_P3.IO6	P3.IO6	14
15	EXT_P3.IO7	P3.IO7	16

#### C.4.19 Internal X9 connector

X9 connector type: 16-pin connector, double-row, 2.54 mm grid

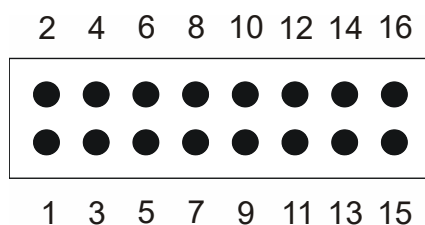

Figure C-27: R&S TS-PTRF X9 connector

Table C-27: R&amp;S TS-PTRF, assignment of the x9 connector

X9			
1	EXT_P4.IO0	P4.IO0	2
3	EXT_P4.IO1	P4.IO1	4
5	EXT_P4.IO2	P4.IO2	6
7	EXT_P4.IO3	P4.IO3	8
9	EXT_P4.IO4	P4.IO4	10
11	EXT_P4.IO5	P4.IO5	12
13	EXT_P4.IO6	P4.IO6	14
15	EXT_P4.IO7	P4.IO7	16

### C.4.20 Internal X41 connector

X41 connector type: 16-pin connector, double-row, 2.54 mm grid

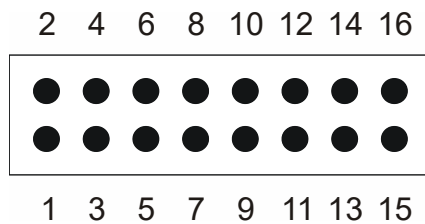

Figure C-28: R&amp;S TS-PTRF X41 connector

Table C-28: R&amp;S TS-PTRF, assignment of the x41 connector

X41			
1	E_CS0	CS0	2
3	E_CS1	CS1	4
5	E_CS2	CS2	6
7	E_CS3	CS3	8
9	E_CS4	CS4	10
11	E_CS5	CS5	12
13	E_CS6	CS6	14
15	E_CS7	CS7	16

### C.4.21 Internal X42 connector

X42 connector type: 6-pin connector, double-row, 2.54 mm grid

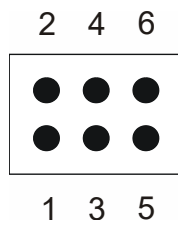

Figure C-29: R&S TS-PTRF X42 connector

Table C-29: R&S TS-PTRF, assignment of the x42 connector

X42			
1	B_SCLK	E_SCLK	2
3	B_MOSI	E_MOSI	4
5	B_MISO	E_MISO	6

#### C.4.22 Internal X32 connector

X32 connector type: 10-pin connector, double-row, 2.54 mm grid

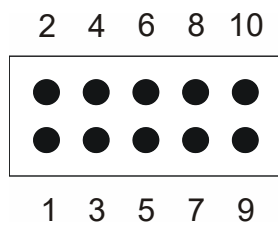

Figure C-30: R&S TS-PTRF X32 connector

Table C-30: R&S TS-PTRF, assignment of the x32 connector

X32			
1	AB_D1	AB_B2	2
3	AB_A1	AB_A2	4
5	AB_B1	AB_D2	6
7	AB_C2	AB_C1	8
9	free	free	10

#### C.4.23 Internal X30 connector

X30 connector type: Special connector 2 mm grid

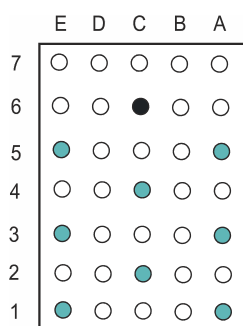

Figure C-31: R&S TS-PTRF X30 connector (view: plug-in side)

Table C-31: R&S TS-PTRF, assignment of the x30 connector

X30	E	D	C	B	A
7					
6			GND		
5	AB_C1				AB_A1
4			AB_B1		
3	AB_C2				AB_B2
2			AB_A2		
1	AB_D2				AB_D1

## C.5 R&S TS-PXM1

### C.5.1 X10 connector on the front

X10 connector type: 96-pin VG connector



Figure C-32: R&S TS-PXM1 X10 connector (view from outside)

Table C-32: R&S TS-PXM1, assignment of the x10 connector

X10	a	b	c
1	X34_1_NC	X34_1	X34_1_NO
2	X34_2_NC	X34_2	X34_2_NO
3	X34_3_NC	X34_3	X34_3_NO
4	X34_4_NC	X34_4	X34_4_NO
5	X34_5_NC	X34_5	X34_5_NO
6	X34_6_NC	X34_6	X34_6_NO
7	X34_7_NC	X34_7	X34_7_NO
8	X34_8_NC	X34_8	X34_8_NO
9	X35_1_NC	X35_1	X35_1_NO
10	X35_2_NC	X35_2	X35_2_NO
11	X35_3_NC	X35_3	X35_3_NO
12	X35_4_NC	X35_4	X35_4_NO
13	X35_5_NC	X35_5	X35_5_NO
14	X35_6_NC	X35_6	X35_6_NO
15	X35_7_NC	X35_7	X35_7_NO
16	X35_8_NC	X35_8	X35_8_NO



X10	a	b	c
17	X36_1_NC	X36_1	X36_1_NO
18	X36_2_NC	X36_2	X36_2_NO
19	X36_3_NC	X36_3	X36_3_NO
20	X36_4_NC	X36_4	X36_4_NO
21	X36_5_NC	X36_5	X36_5_NO
22	X36_6_NC	X36_6	X36_6_NO
23	X36_7_NC	X36_7	X36_7_NO
24	X36_8_NC	X36_8	X36_8_NO
25	X37_1_NC	X37_1	X37_1_NO
26	X37_2_NC	X37_2	X37_2_NO
27	X37_3_NC	X37_3	X37_3_NO
28	X37_4_NC	X37_4	X37_4_NO
29	X37_5_NC	X37_5	X37_5_NO
30	X37_6_NC	X37_6	X37_6_NO
31	X37_7_NC	X37_7	X37_7_NO
32	X37_8_NC	X37_8	X37_8_NO

### C.5.2 Control: connector X33

X33 connector type: 20-pin connector, double-row, 2 mm grid

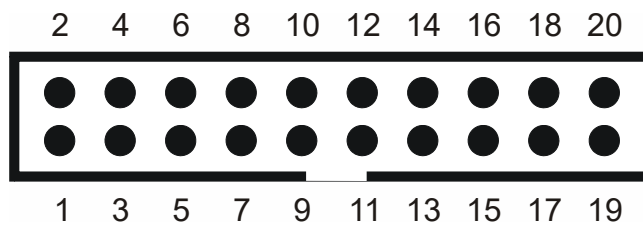

Figure C-33: R&S TS-PXM1 X33 connector

Table C-33: R&S TS-PXM1, assignment of the x33 connector

X33			
1	GND	bit0 (K1/K2)	2
3	bit1 (K3/K4)	bit2 (K5/K6)	4
5	bit3 (K7/K8)	bit4 (K9/K10)	6
7	bit5 (K11/K12)	bit6 (K13/K14)	8
9	bit7 (K15/K16)	free	10
11	SCLK	MOSI	12

X33			
13	MISO	CS	14
15	free	free	16
17	+5V	+5V	18
19	+12V	GND	20

### C.5.3 Connectors X34 to X37

X34-X37 connector type: 8-pin connector, double-row, 2.54 mm grid

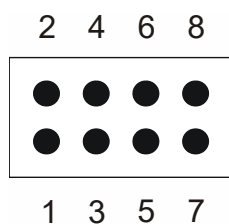

*Figure C-34: R&S TS-PXM1 connectors X34 to X37*

The signal names are identical to those of the pins.

Example: X34.Pin1 = signal name X34\_1.

The pins are wired to the VG connector (X10) column „B“ (refer to Table 6-4).